

BACnet Quick Start Guide

1 – Wire Network Connection

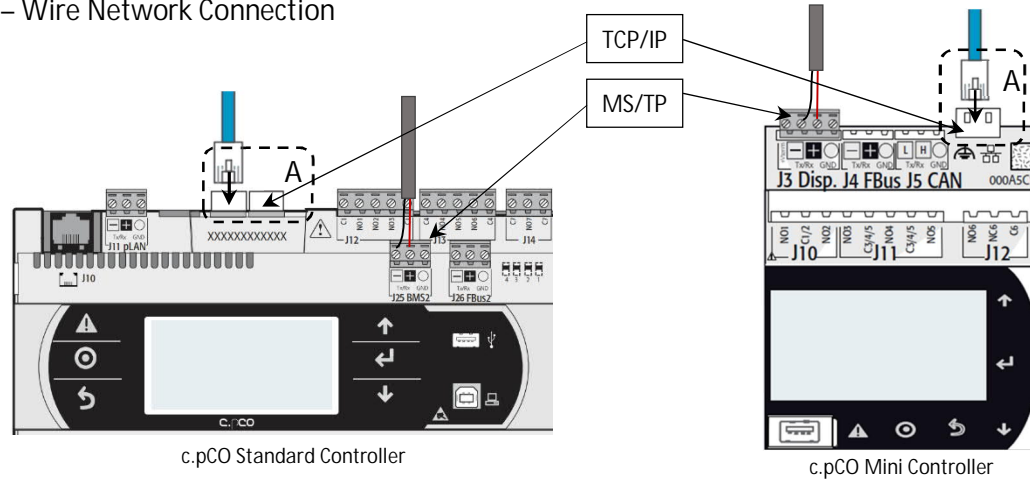

A – Ethernet Port Lights

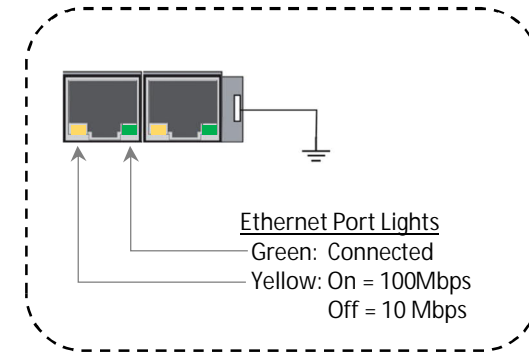

2 – Adjust BACnet Network Settings

Menu Structure Reference	
⊙	Main Menu
↓	Ctrl Variables
↓	Advanced
↓	Login
↓	Network Settings

2.1 – Enter User Password

```

User Login
Enter Password: 9998
-----
Current Access:
Read Only
    
```

2.2 – BACnet MS/TP Settings

```

BACnet MS/TP Config
Device: 0077077
Info Frames: 20
Max Masters: 127
Mstr Address: 77
Baud Rate: 9600
Save Settings: 
    
```

2.2 – BACnet IP Settings

```

PCU Board Address
Enable DHCP: 
IP: 192.168. 0.100
Mask: 255.255.255. 0
GW: 192.168. 0. 1
DNS: 192.168. 0. 1
Save Changes: 
    
```

```

BACnet IP Config
Device: 0077077
Port: 0047808
    
```

3 – Command Unit Operation

1. Enable Unit
2. Control Occupancy
3. Reset Alarms
4. Global Alarm Notification
5. Control Temperature Setpoint (optional)

Object	Object Name	Object Description	Active Text	Inactive Text
			Variable Type	
BV-2	System_Enable	Master system enable/disable point.	Enabled	Disabled
BV-3	BMS_Occupancy_Command	Occupancy Command	Unoccupied	Occupied
BV-4	Reset_All_Alarms	Alarm Reset Command	Reset	Normal
BV-23	Global_Alarm	Alarm Notification (any alarm by default)	Alarm	Normal
AV-1	Temperature_Setpoint	Sets the active temperature set-point based on mode of operation (space setpoint, return setpoint or supply setpoint). Not applicable for outside reset.	Default = 72°F Min = 50°F; Max = 100°F	

Reference Guide for BACnet Integration

Please read and save these instructions for future reference. The information in this guide assumes the controller was already configured with BACnet based on the original sales configuration. If the controller does not have BACnet enabled, please contact the equipment representative to get the necessary licensing and configuration files to allow BACnet communication to be used.

DOAS_08.000 Rev 2
Document Date: 01/2023

Basic Unit Integration

Below are the basic integration functions available on all equipment regardless of control mode. Some features are unit configuration dependent (heating type, cooling type, etc.). The controller's BMS points list is static regardless of configuration to accommodate field configuration changes, however, not all points are applicable to every unit. Once the required sensors are installed in the equipment, the only mandatory requirements to make the unit operational are to enable the unit, if it hasn't been enabled manually at the controller, and to command occupancy as desired.

Object	Variable	Description	Active Text	Inactive Text
Unit Enable/Disable Operation				
If desired, the unit can be enabled and disabled by the BMS system. In disabled mode, certain safety sequences may operate to protect the building and/or equipment but general heating, cooling and ventilation operation will not function.				
BV-2	System_Enable	Master system enable/disable command	Enabled	Disabled
Unit Occupancy Control				
By default, the unit occupancy is expected to be commanded by the BMS occupancy point. Alternatively, the unit occupancy can be controlled by an internal schedule, set to always unoccupied, always occupied or controlled by a digital input by changing the occupancy mode selection at the controller.				
If the controller is configured for warm-up/cool-down mode, after the occupancy command is received the unit will run in unoccupied recirculation mode until reaching the occupied temperature setpoint or the warm-up/cool down time expires (default 30 minutes) at which point the controller will enter normal occupied mode operation.				
BV-3	BMS_Occupancy_Command	Building Occupancy Command	Unoccupied	Occupied
Alarms				
The following points allow the notification of any alarm and the last alarm triggered to be read, as well as active alarms that to be manually reset remotely. See the unit's full BMS points list if specific alarm monitoring or trending is desired.				
BV-4	Reset_All_Alarms	Alarm Reset Command	Reset	Normal
BV-23	Global_Alarm	Global Alarm	Alarm	Normal
IV-5	LatestAlm	Most recent active alarm	See Alarm Table (0 = No Active Alarm)	
Monitoring Unit Operation				
Unit status				
AV-40	Unit_Status_Mode	Unit Operation Mode/State	See Status Mode Table	
Fans and Dampers				
BI-1	Exhaust_Fan_1_Status_Digital_Input	Exhaust Fan 1 Status	Active	Inactive
BI-2	Supply_Fan_1_Status_Digital_Input	Supply Fan 1 Status	Active	Inactive
AV-73	Exhaust_Fan_Speed_Analog_Output	Exhaust Fan Speed Analog Output	Real (%)	
AV-78	Outside_Air_Damper_Analog_Output	Outside Air Damper Analog Output	Real (%)	
AV-79	Supply_Fan_Speed_Analog_Output	Supply Fan Speed Analog Output	Real (%)	
Cooling				
IV-11* (Bit 20)	Cooling_is_On	Indicates that the unit is cooling	Active	Inactive
AV-42	Cooling_1_Ramp_Capacity	Cooling Ramp 1 Status Value	Real (%)	
Heating				
IV-11* (Bit 21)	Heating_is_On	Indicates that the unit is heating	Active	Inactive
AV-51	Heating_Capacity	Heating Ramp	Real (%)	
Filters				
IV-10* (Bit 13)	Filter_Alarm_Digital_Input	Filter Alarm Digital Input Status	Alarm	Normal

Object	Variable	Description	Active Text	Inactive Text
Energy Recovery				
IV-10* (Bit 0)	Heat_Wheel_Enable_Digital_Output	Heat Wheel Enable Digital Output	Active	Inactive
IV-10* (Bit 18)	Wheel_Rotation_Alarm	Heat Wheel Rotation Alarm	Alarm	Normal
AV-72	Energy_Recovery_Analog_Output	Energy Recovery Analog Output	Real (%)	
Refrigeration Systems				
IV-6* (Bit 0)	Compressor_1_Enable_Digital_Output	Compressor 1 Enable Digital Output	Active	Inactive
IV-6* (Bit 1)	Compressor_2_Enable_Digital_Output	Compressor 2 Enable Digital Output	Active	Inactive
IV-6* (Bit 2)	Compressor_3_Enable_Digital_Output	Compressor 3 Enable Digital Output	Active	Inactive
IV-6* (Bit 3)	Compressor_4_Enable_Digital_Output	Compressor 4 Enable Digital Output	Active	Inactive
AV-50	HP_Ramp_Capacity	Heat Pump Heating Ramp	Real (%)	
AV-53	Hot_Gas_Reheat_Ramp	Hot Gas Reheat Ramp	Real (%)	
AV-80	Modulating_Compressor_Analog_Output_BMS	Modulating Compressor Analog Output	Real (%)	
Chilled Water Systems				
AV-68	Chilled_Water_1_Valve_Analog_Output	Chilled Water 1 Valve Analog Output	Real (%)	
Hot Water Systems				
AV-74	Hot_Water_Valve_1_Analog_Output	Hot Water Valve 1 Analog Output	Real (%)	
IG Furnaces				
IV-6* (Bit 16)	Furnace_1_Stage_1_Digital_Output	Furnace 1 Stage 1 Digital Output	Active	Inactive
IV-6* (Bit 17)	Furnace_2_Stage_1_Digital_Output	Furnace 2 Stage 1 Digital Output	Active	Inactive
AV-76	Mod_Gas_Furnace_1_Analog_Output	Mod Gas Furnace 1 Analog Output	Real (%)	
Electric Post-Heat				
AV-70	Electric_Heater_1_Analog_Output	Electric Heater 1 Analog Output	Real (%)	
Electric Pre-Heat				
IV-10* (Bit 1)	PreHeat_Enable_Digital_Output	PreHeat Enable Digital Output	Active	Inactive
Sensor Values (when equipped)				
AI-1	Space_Temp_Analog_Input	Space Air Temperature	Real (°F)	
AI-2	Supply_Temp_Analog_Input	Supply(discharge) Air Temperature	Real (°F)	
AI-3	Outside_Air_Temp_Analog_Input	Outside Air Temperature	Real (°F)	
AI-4	Mixed_Temp_Analog_Input	Mixed Air Temperature	Real (°F)	
AI-5	Cold_Coil_1_Temp_Analog_Input	Cold Coil 1 Leaving Air Temperature	Real (°F)	
AI-7	Return_Temp_Analog_Input	Return Air Temperature	Real (°F)	
AI-8	Exhaust_Temp_Analog_Input	Exhaust Air Temperature	Real (°F)	
AI-9	Space_RH_Analog_Input	Space Air Relative Humidity	Real (% RH)	
AI-10	Outside_RH_Analog_Input	Outside Air Relative Humidity	Real (% RH)	
AI-11	Return_RH_Analog_Input	Return Air Relative Humidity	Real (% RH)	
AI-12	Return_Duct_Static_Pressure_Analog_Input	Return Duct Static Pressure	Real ("wc)	
AI-13	Space_Static_Pressure_Analog_Input	Space Static Pressure	Real ("wc)	
AI-14	Supply_Duct_Static_Pressure_Analog_Input	Supply Duct Static Pressure	Real ("wc)	
AI-15	Space_CO2_1_Analog_Input	Space 1 CO2 ppm	Real (ppm)	
AI-17	Return_CO2_Analog_Input	Return CO2 ppm	Real (ppm)	
AV-64	Total_Exhaust_Fan_CFM_BMS	Total Exhaust Fan CFM	Real (cfm)	
AV-65	Total_Supply_Fan_CFM_BMS	Total Supply Fan CFM	Real (cfm)	
AV-66	OAD_CFM_BMS	Outdoor Air Damper CFM	Real (cfm)	
Active Setpoints				
AV-41	Supply_Temperature_Calculated_Setpoint	Active Supply Temperature Setpoint	Real (°F)	
AV-90	Coil_Temperature_Calculated_Setpoint	Calculated Coil Leaving Set point	Real (°F)	

* Please see [Binary Tables](#).

Unpacking Integer Words to Binary Values

Binary values can be combined to create an integer word. By doing this, more information is available to the BMS in a smaller number of points and less network traffic. These integer words need to be "unpacked" once the BMS receives the value.

To unpack the integer word into the binary values, the integer needs to be converted to a binary number. The integers in the program are 32-bit, meaning up to 32 binary values are packed into the integer. Each bit can either be a 0 (Inactive) or a 1 (Active).

The BMS front end may have a solution already intact to pull individual bits from an integer. A "read bit" function looks to return what value a certain bit is in an integer. Bit number are 0-31 in a 32-bit integer with 0 being the lowest bit and the furthest to the right in the binary notation of the number. Bit 31 would be the largest bit and the furthest to the left in binary notation.

If the front end does not have a "read bit" or "bit extract" function, the binary value of individual bits can be determined by continually dividing the quotient of the integer by 2, the remainder of the division is the value of the bit (0 or 1). A function called Modulo or "mod" is commonly used to return the remainder of integer division.

Equation: $x = (\text{round down}(a/2^b)) \text{ mod } 2$

- x is Boolean value for bit b, where 0 is inactive and 1 is active.
- a is the integer word value
- b is the bit of the binary number used as an exponent
- The result of $a/2^b$ should round down to a whole number, truncating the decimal. For example, $5/2^1$ is 2.5, however, only the 2 is used.

Example:

If the Device_Offline_Word (IV-8) is a decimal value of 11, the binary value would be 1011. This binary value would mean that Space Thermostats 1, 2, and 4 are offline. The rest of the bits in the binary number would be a Boolean value of 0. (Please see [Binary Tables](#).)

- Bit 0 = $11/2^0 \text{ mod } 2$... this results in a Boolean of 1 or Active for bit 0.
- Bit 1 = $11/2^1 \text{ mod } 2$... this results in a Boolean of 1 or Active for bit 1.
- Bit 2 = $11/2^2 \text{ mod } 2$... this results in a Boolean of 0 or Inactive for bit 2.
- Bit 3 = $11/2^3 \text{ mod } 2$... this results in a Boolean of 1 or Active for bit 3.

Bit	31	30	29	28	27	26	25	24	23	22	21	20	19	18	17	16	15	14	13	12	11	10	9	8	7	6	5	4	3	2	1	0
Val	0	0	0	0	0	0	0	0	0	0	0	0	0	0	0	0	0	0	0	0	0	0	0	0	0	0	0	0	1	0	1	1

Modifying Equipment Operation

In addition to commanding unit occupancy, some system level sequences may require feedback from the BMS. Common BMS adjusted sequences include items like supply air temperature reset control, demand control ventilation for multiple zones, and duct static pressure reset.

HEATING AND COOLING OPERATION SETPOINTS

Object	Variable	Description	Active Text	Inactive Text
Adjusting Temperature Setpoints				
Controller Provided Sequences – Occupied Mode				
The controller has several stand-alone supply air temperature control modes with setpoints that can be modified by the BMS. These modes include a static supply air temperature setpoint (no-reset) or allows for the supply air temperature setpoint to be reset based on outside air temperature, space temperature, or return air temperature.				
IV-1	Temperature_Reset_Mode	Commands the reset mode during occupied operation.	1 = No Reset, 2 = Space Reset 3 = Return Reset, 4 = Outside Reset	
AV-1	Temperature_Setpoint	Sets the temperature setpoint based on mode of operation (space setpoint, return setpoint or supply setpoint). Not applicable for outside reset.	Real, Default = 72°F *Min = 50°F; Max = 100°F	
AV-2	Temperature_Heat_Cool_Deadband	Heat/Cool Setpt Deadband when Space or Return reset control is active. Htg Setpt = Temp Setpt - Deadband /2 Clg Setpt = Temp Setpt + Deadband /2	Real, Default = 4°F *Min = 0.5°F; Max = 20°F [Space/Return Heating = 70°F, Space/Return Cooling = 74°F]	

* Typical range for standard configuration unit, please verify at point min and max properties.

Object	Variable	Description	Active Text	Inactive Text
Controller Provided Sequences – Unoccupied Mode				
When the unoccupied mode of operation is set to night setback temperature, normal operation with unoccupied setpoints, or recirculation with unoccupied setpoints, the following setpoints control unoccupied heating and cooling operation. If night setback is selected as the Unoccupied Mode of operation, the reset mode will not be available to change at the controller and should be set to Space Reset(2).				
IV-2	Temperature_Reset_Mode_Unoccupied	Commands the reset mode during occupied operation.	1 = No Reset, 2 = Space Reset 3 = Return Reset, 4 = Outside Reset	
AV-3	Temperature_Setpoint_Unoccupied	Sets the temperature setpoint based on mode of operation (space setpoint, return setpoint or supply setpoint). Not applicable for outside reset.	Real, Default = 70°F *Min = 50°F; Max = 100°F	
AV-4	Temperature_Heat_Cool_Deadband_Unoccupied	Heat/Cool Setpt Deadband when Space or Return reset control is active. Unocc Clg Setpt = Temp Setpt Unocc + (Deadband Unocc)/2 Unocc Htg Setpt = Temp Setpt Unocc + (Deadband Unocc)/2	Real, Default = 20°F *Min = 0.5°F; Max = 40°F [Space/Return Heating = 60°F, Space/Return Cooling = 80°F]	
BMS Controlled Sequences				
BMS control over reset write to temp setpoint and have mode in No reset.				

* Typical range for standard configuration unit, please verify at point min and max properties.

DEHUMIDIFICATION OPERATION SETPOINTS

Object	Variable	Description	Active Text	Inactive Text
Dehumidification Setpoints				
The unit controller will enter occupied dehumidification mode when the dehumidification trigger(s) is met. During dehumidification mode, the cooling system is controlled to maintain the cooling coil leaving air temperature setpoint while the hot gas reheat system (if installed) reheats the air to maintain the active supply air temperature setpoint. For units with space or return humidity sensors, the controller may also actively reset the cooling coil temperature setpoint between minimum and maximum values to maintain the target space/return dehumidification setpoint (% RH). Note: By default, unoccupied dehumidification mode is not active unless a trigger to enter the mode is selected at the unit controller since most spaces do not have an unoccupied dehumidification load.				
AV-5	Cooling_Coil_Setpoint_Min	Primary Cooling Coil Leaving Air Setpoint	Default = 50°F *Min = 46°F; Max = 80°F	
AV-6	Cooling_Coil_Setpoint_Max	Maximum Coil Leaving Setpoint if cooling coil rest strategy is used.	Default = 55°F *Min = 46°F; Max = 80°F	
AV-7	Dehumidification_Setpoint	Dehumidification Setpoint. %RH for Space or Return control	Default = 55% RH Min = 0%; Max = 100%	
AV-11	Unoccupied_Dehumidification_Setpoint	Unoccupied Dehumidification %RH Setpoint	Default = 60% RH Min = 0%; Max = 100%	

* Typical range for standard configuration unit, please verify at point min and max properties.

AIRFLOW OPERATION SETPOINTS

Object	Variable	Description	Active Text	Inactive Text
Airflow Setpoints				
Airflow operation of supply fan, exhaust fan, and mixing dampers may use setpoints from duct pressure, space pressure, CO2 sensors, or airflow measuring stations to properly control airflow in an application. The Outside Air Damper Minimum Setpoint Occupied applies to all units with modulating outside air dampers. The setpoint is used to establish an absolute minimum position for ventilating the space while allowing other control modes to open the damper further as necessary. Outdoor and recirculating air dampers operate inversely using the same signal.				
AV-14	Supply_Fan_CFM_Setpoint	Supply Fan CFM Setpoint	Default = Job Specified CFM Min = 0 cfm; Max = 999,999 cfm	
AV-15	Exhaust_Fan_CFM_Setpoint	Exhaust Fan CFM Setpoint	Default = Job Specified CFM Min = 0 cfm; Max = 999,999 cfm	
AV-16	OAD_CFM_Setpoint	OAD CFM Setpoint	Default = Job Specified CFM Min = 0 cfm; Max = 999,999 cfm	
AV-21	Return_Duct_Static_Pressure_Setpoint	Return Duct Static Pressure Setpoint	Default = -2.0"wc Min = 0.0"wc; Max = -5.0"wc	
AV-22	Space_Static_Pressure_Setpoint	Space Static Pressure Setpoint	Default = 0.05"wc Min = -0.5"wc; Max = 0.5"wc	
AV-23	Supply_Duct_Static_Pressure_Setpoint	Supply Duct Static Pressure Setpoint	Default = 1.0"wc Min = 0.0"wc; Max = 5.0"wc	
AV-24	Space_CO2_Setpoint	Space CO2 Setpoint	Default = 1,000 ppm Min = 0 ppm; Max = 5,000 ppm	
AV-25	Outside_Air_Damper_Minimum_Setpoint_Occ	Outside Air Damper Minimum Setpoint Occupied	Default = 35% Min = 0%; Max = 100%	

BMS Watchdog Enabled Control

BMS WATCHDOG

When directly commanding fans speeds, damper positions, or sending sensor values, the unit controller requires the BMS Watchdog point to be written to on a recurring basis. This tells the unit controller that the BMS is still actively communicating.

Object	Variable	Description	Active Text	Inactive Text
BMS Watchdog				
The BMS Watchdog must be written to True (1) regularly to verify communication is established between the unit controller and the BMS headend system. If the BMS Watchdog value remains False(0) for longer than the Timeout Delay (15 minutes, adjustable), an alarm is generated and the controller falls back to local control and sensor values, as applicable, instead of using BMS commanded values.				
BV-1	BMS_Watchdog	BMS Watchdog command	Active	Inactive
BV-24	BMS_Watchdog_Active	Status of the BMS watchdog ping.	Active	Inactive

CONTROLLING AIRFLOW DEVICES

If desired, the speeds and positions of airflow devices can be controlled directly using BACnet commandable points. To control the devices via the BMS, the BMS Watchdog requirements must be satisfied.

Object	Variable	Description	Active Text	Inactive Text
Fan Controls				
Fan speeds can be controlled directly through BMS points. The binary points enable the BMS to take control and the analog values command the speeds as a percentage between the allowed minimum and maximum values set in the controller.				
Supply Fan				
BV-17	SF_Control_Source_BMS	Allows the BMS to control supply fan speed	BMS	Local
AV-36	SF_Control_Signal_BMS	Supply Fan Command Speed	Real (%) *Min=50%; Max=100%	
Exhaust Fan				
BV-18	EF_Control_Source_BMS	Allows the BMS to control exhaust fan speed	BMS	Local
AV-37	EF_Control_Signal_BMS	Exhaust Fan Command Speed	Real (%) Min=25%; Max=100%	
Outdoor Air/Recirculation Air Damper Control				
The outdoor air damper position can be controlled directly by the BMS to adjust the mixture of outdoor air and recirculation air on units configured for recirculation. Minimum and maximum values for occupied and unoccupied mode set at the unit controller are enforced.				
BV-19	OAD_Control_Source_BMS	Allows the BMS to control OAD position	BMS	Local
AV-38	OAD_Control_Signal_BMS	Outside Air Damper Control Signal via BMS	Real (%) Min=0%; Max=100%	

* Typical range for standard configuration unit, please verify at point min and max properties.

SENDING SENSOR VALUES

Sensor values required for sequence operation can be sent to the controller over dedicated BMS points in place of a sensor wired to the controller (local sensor). When values are communicated to the controller over BMS, the BMS Watchdog must be satisfied. If the watchdog isn't satisfied, the controller reverts to the local sensor (if installed and valid) to control the unit or falls back to local control until the BMS watchdog is satisfied.

Object	Variable	Description	Active Text	Inactive Text
BMS Writeable Sensor Values				
To write the sensor values over BMS, first command the controller to use the BMS value using the corresponding binary value and then use the corresponding analog value to send the sensor value.				
Sensor Sources				
BV-7	Outside_RH_Source_BMS	Outside RH Source Selection	BMS	Local
BV-8	Outside_Temp_Source_BMS	Outside Temp Source Selection	BMS	Local
BV-9	Return_RH_Source_BMS	Return RH Source Selection	BMS	Local
BV-10	Return_Temp_Source_BMS	Return Temp Source Selection	BMS	Local
BV-11	Space_1_CO2_Source_BMS	Space 1 CO2 Source Selection	BMS	Local
BV-12	Space_2_CO2_Source_BMS	Space 2 CO2 Source Selection	BMS	Local
BV-13	Return_CO2_Source_BMS	Return CO2 Source Selection	BMS	Local
BV-14	Space_RH_Source_BMS	Space RH Source Selection	BMS	Local
BV-15	Space_Static_Source_BMS	Space Static Source Selection	BMS	Local
BV-16	Space_Temp_Source_BMS	Space Temp Source Selection	BMS	Local

Object	Variable	Description	Active Text	Inactive Text
Sensor Values				
AV-26	Outside_RH_from_BMS	Outside RH from BMS.		Real (% RH)
AV-27	Outside_Temp_from_BMS	Outside Temp from BMS		Real (°F)
AV-28	Return_RH_from_BMS	Return RH from BMS		Real (% RH)
AV-29	Return_Temp_from_BMS	Return Temp from BMS		Real (°F)
AV-30	Space_1_CO2_from_BMS	Space 1 CO2 from BMS		Real (ppm)
AV-31	Space_2_CO2_from_BMS	Space 2 CO2 from BMS		Real (ppm)
AV-32	Return_CO2_from_BMS	Return CO2 from BMS		Real (ppm)
AV-33	Space_RH_from_BMS	Space RH from BMS		Real (% RH)
AV-34	Space_Static_from_BMS	Space Static from BMS		Real (*wc)
AV-35	Space_Temp_from_BMS	Space Temp from BMS		Real (°F)

Advanced BACnet Settings

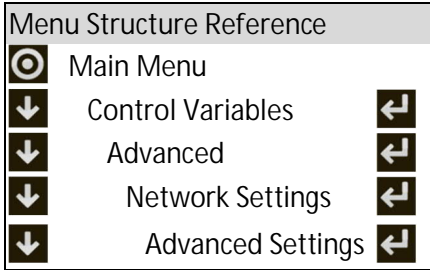

Additional settings can be accessed in the BACnet Advanced Settings menu including BACnet Broadcast Management Device (BBMD) configuration, relinquish default settings, Change of Value (COV) increments and restoring binary text values.

BBMD CONFIGURATION

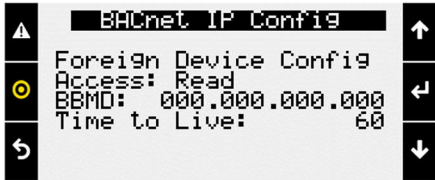

To configure the controller to operate with a BACnet Broadcast Management Device (BBMD) on IP networks, go to the advanced BACnet settings menu and enter the IP address of the BBMD, foreign device configuration, and time to live settings.

COV INCREMENTS

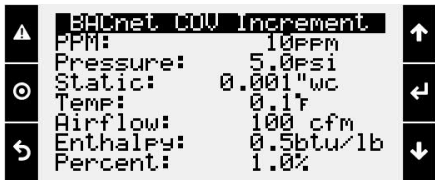

BACnet COV is an optional portion of BACnet that supports providing new values/information only after an increase or decrease of the value is at least the listed COV increment. The controller's COV increments are based on the unit of measure. All variables with the same unit of measure share the same COV increment value. Values can be adjusted on this screen, or by writing to the COV increment property of any BACnet object.

RELINQUISH DEFAULT SETTINGS

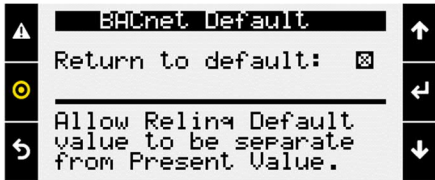

When the Return to Default function is enabled, the present value will not overwrite the relinquish default value and on a loss of power the controller will boot with last saved default values instead of last written values. This must also be enabled for the BACnet Comm Loss relinquish default to work.

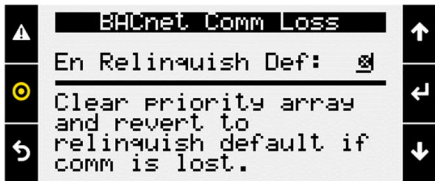

When the Enable Relinquish Default function is enabled any value in the priority array for binary values or analog values will be cleared if a communication loss is detected. All commandable points will revert to the relinquish default value.

Communication loss is determined based on the BMS Watchdog. The watchdog function must be enabled. The function will execute 5 minutes after the watchdog status goes inactive.

This may be desired if the BMS is running a reset routine on the setpoints and would like to revert to a default state if communication is lost. It is recommended to be used with return to default enabled, and a known relinquish default is saved.

When this box is checked by a user, the controller will write the present value of variables to the relinquish default for all binary and analog value BACnet objects that are commandable. The function operates in the background and takes approximately 30 seconds to complete.

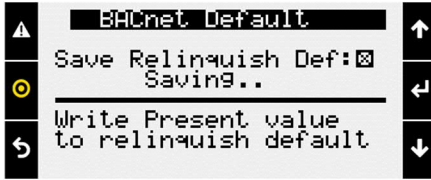

This is desired to save any Test and Balance settings adjusted locally on the controller to be the BACnet relinquish default values. Alternatively, these values could be read and written to the relinquish default variables by the BMS system.

BINARY TEXT

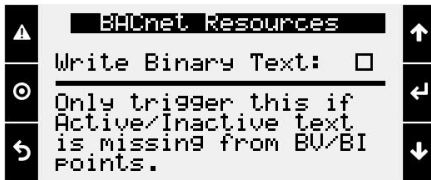

If for any reason, the state text is missing from binary objects, checking this box will cause the controller to re-write the active and inactive text values.

DOAS Reference Tables

STATUS MODE TABLE

The following analog values can appear in the point to tell the building automation the current mode of operation of the unit. Values may rotate every three seconds.

Status Mode Table (AV-40)					
Analog Value	Mode	Analog Value	Mode	Analog Value	Mode
0	Off/Standby	12	System Disabled	23	Dehumidifying
1	Unoccupied Start	13	Remote Off	25	Hot Gas Reheat Purging
2	Occupied Start	14	System Shutdown Alarm	26	Energy Recovery Defrost Active
3	Opening Dampers	15	Pressurization Only	29	Dehumidifying with Heat
5	Dampers Open	16	Exhaust Only	30	Manual Overrides Active
6	Fan Start Delay	17	Fan Only Purge	31	Expansion Board Offline
7	Exhaust Fan Start	18	Case Heat Active	33	Energy Recovery Active
8	Supply Fan Start	19	Fans Only	34	Hot Gas Reheat Active
9	Heat/Cool Startup Delay	20	Economizing	35	Morning Occupancy Sequence
10	System On	21	Cooling	36	Heat Pump Defrost Active
11	Soft Shutdown	22	Heating		

ALARM TABLE

This table displays the latest alarm that is active in the unit controller.

Alarm Table - Latest Alarm (IV-5)			
0	No Active Alarms	94	Sens S1 EVD 1 - Sensor Value Not Valid
1	Supply Fan 1 Run - Status Not Proven	95	Sens S2 EVD 1 - Sensor Value Not Valid
2	Freeze Protection - Thermostat Tripped	96	Sens S3 EVD 1 - Sensor Value Not Valid
3	High Supply Duct - Static Pressure	97	Sens S4 EVD 1 - Sensor Value Not Valid
4	Low Return Duct - Static Pressure	98	EVD 1 EEPROM Damaged - Call Tech Support
5	Outside Air Temp - Sensor Value Not Valid	99	Incomplete Closing - EVD 1
6	Supply Air Temperature - Sensor Value Not Valid	100	Emergency Closing - EVD 1
7	Cold Coil 1 Temp - Sensor Value Not Valid	101	EVD 1 Battery -
9	Exhaust Air Temp - Sensor Value Not Valid	102	FW Incompatibility - EVD 1
10	Mixed Air Temperature - Sensor Value Not Valid	103	EVD 1 Config Error -
11	Return Air Temperature - Sensor Value Not Valid	104	EVD 1 Comm - EVD 1 is Offline
12	Space Temperature - Sensor Value Not Valid	105	High Discharge Temp - First Inverter

Alarm Table - Latest Alarm (IV-5)

13	Return Air RH - Sensor Value Not Valid	106	Low Discharge Pressure - First Inverter
14	Space RH - Sensor Value Not Valid	107	High Suction Pressure - First Inverter
15	Outside RH - Sensor Value Not Valid	108	Low Suction Pressure - First Inverter
16	Low Pressure Switch - Circuit A	109	High Current - First Inverter
17	Low Pressure Switch - Circuit B	110	High Pressure Ratio - First Inverter
20	High Pressure Switch - Circuit A	111	Low Pressure Ratio - First Inverter
21	High Pressure Switch - Circuit B	112	Low Delta P - First Inverter
24	Damper End Switch Fail - Dampers are not open	113	High Discharge Press - First Inverter
25	Exhaust Fan 1 Run - Status Not Proven	114	Compressor Staging - Order Skipped
26	Filters are Dirty - Replace Filters	115	Heat Pump Heating - Locked Out
27	Cond Drain Pan Full - Check Drain	116	EVD 1 Error - Unexpected Position
28	Exp Board 1 Status - Board is Offline	117	High SDT Lockout - Circuit A
29	Exp Board 2 Status - Board is Offline	118	High SDT Lockout - Circuit B
31	Exp Board 4 Status - Board is Offline	121	Inverter 1 Alarm -
32	Non-Volatile Memory Er - Contact Tech Support	123	Inverter 1 Lockout - Cycle Power to Unit
33	Space 1 CO2 - Sensor Value Not Valid	125	Inverter 1 Foldback - Output Current
34	Space Static Pressure - Sensor Value Not Valid	126	Inverter 1 Foldback - Input Current
35	Supply Duct Stat Press - Sensor Value Not Valid	127	Inverter 1 Foldback - Inverter Temp
36	Return Duct Stat Press - Sensor Value Not Valid	131	Inverter 1 Comms Lost - Compressor Offline
37	Supply Fan AFMS - Sensor Value Not Valid	133	Space Thermostat 1 - Sensor Offline
38	Exhaust Fan AFMS - Sensor Value Not Valid	134	Space Thermostat 2 - Sensor Offline
39	Outside Damper AFMS - Sensor Value Not Valid	135	Space Thermostat 3 - Sensor Offline
40	Space Setpt Adj Slider - Sensor Value Not Valid	136	Space Thermostat 4 - Sensor Offline
41	Space 2 CO2 - Sensor Value Not Valid	137	IG Furnace 1. No flame - after 3 tries
42	Return CO2 - Sensor Value Not Valid	138	IG Furnace 1 Large - no flame after 3 tries
43	Discharge Press Ckt A - Sensor Value Not Valid	139	IG Furnace 1 combust - fan high pressure switch
44	Discharge Press Ckt B - Sensor Value Not Valid	140	IG Furnace 1 Ignition - controller alarm
47	Suction Press Ckt A - Sensor Value Not Valid	141	IG Furnace 1 pressure - switch fault alarm
48	Suction Press Ckt B - Sensor Value Not Valid	142	IG Furnace 1 combust - fan proving alarm
51	Discharge Temp Ckt A - Sensor Value Not Valid	143	IG Furnace 1 - Max Retries
52	Discharge Temp Ckt B - Sensor Value Not Valid	144	IG Furnace 1 - High Limit Trip
55	Suction Temp Ckt A - Sensor Value Not Valid	145	IG Furnace 1 - pCOe 1 Offline
56	Suction Temp Ckt B - Sensor Value Not Valid	146	IG Furnace 1 IC fault - Check Furnace Wiring
59	Ckt A High Saturated - Discharge Temperature	147	IG Furnace 2 No flame - after 3 tries
60	Ckt B High Saturated - Discharge Temperature	148	IG Furnace 2 Large - no flame after 3 tries
63	Supply Air Temperature - Low Limit Shutdown	149	IG Furnace 2 combust - fan high pressure switch
64	Heat Wheel Rotation - Not Detected	150	IG Furnace 2 Ignition - controller alarm
65	Slave Unit 1 Offline -	151	IG Furnace 2 pressure - switch fault alarm
66	Slave Unit 2 Offline -	152	IG Furnace 2 combust - fan proving alarm
67	Slave Unit 3 Offline -	153	IG Furnace 2 - Max retries
68	Slave Unit 4 Offline -	154	IG Furnace 2 - High Limit Trip
69	Master Unit Offline -	155	IG Furnace 2 - pCOe 2 Offline
70	Heat Pump Defrost - Mode is Active	156	IG Furnace 2 IC fault - Check Furnace Wiring
71	Multi Devices per Ch - Contact Tech Support	157	Outside Air GreenTrol - Offline or Flow Error
74	Shutdown Contact - In Alarm Position	158	Exhaust Air GreenTrol - Offline or Flow Error
75	Comp Maintenance Alarm - Run Hours Setpt Reached	159	Supply Air GreenTrol - Offline or Flow Error
76	Supply Air Temperature - High Limit Shutdown	169	ER Wheel High - Differential Pressure
77	Space High Static Pres - Shutdown	170	OA Damper Fault - Not Econ and should be
78	Internal Board Temp - Exceeds -40F or 158F	171	OA Damper Fault - Econ and shouldn't be
79	BMS Offline - Watchdog is FALSE	172	OAD Fault - Damper not Modulating
80	Cooling Coil Setpt Input - Value is not valid	173	OAD Fault - Excess Outdoor Air
81	Sup Air Setpt Input - Value is not valid	174	IG Furnace 1 - Combustion Fan Alarm
82	BACnet License - Not Installed	175	IG Furnace 2 - Combustion Fan Alarm
83	Low Suction SH ExV A - EVD 1 Alarm	176	Supply Fan - VFD Offline
84	Low Suction SH ExV B - EVD 1 Alarm	177	Exhaust Fan - VFD Offline
85	LOP A EVD 1 - Low Operating Pressure	178	Return Fan - VFD Offline
87	MOP A EVD 1 - Max Operating Pressure	179	Energy Recovery - VFD Offline
89	EEV A EVD 1 - Motor Alarm	180	Embedded EVD Error
91	Low Suction A EVD 1 - Refrigerant Temp	181	SF VFD Alarm - Check VFD
93	High Condensing Temp - EVD 1		

BIT-PACKED INTEGER WORD TABLES

The following tables are used to unpack integer words into Boolean values.

Device Enable DO Word Table (IV-6)					
Bit	Device_Enable_DO_Word	Bit	Device_Enable_DO_Word	Bit	Device_Enable_DO_Word
0	Compressor 1 Start	11		22	
1	Compressor 2 Start	12	Condenser Fan Ramp 2 Stage 1 Start	23	
2	Compressor 3 Start	13	Condenser Fan Ramp 2 Stage 2 Start	24	
3	Compressor 4 Start	14	Condenser Fan Ramp 2 Stage 3 Start	25	
4		15		26	
5		16	Furnace 1 Start	27	
6		17	Furnace 2 Start	28	
7		18		29	
8	Condenser Fan Ramp 1 Stage 1 Start	19		30	
9	Condenser Fan Ramp 1 Stage 2 Start	20	Supply Fan Start	31	
10	Condenser Fan Ramp 1 Stage 3 Start	21	Exhaust Fan Start		

Refrigeration Circuit Word Table (IV-7)					
Bit	Ref_Ckt_PressTemp_Alarm_Word	Bit	Ref_Ckt_PressTemp_Alarm_Word	Bit	Ref_Ckt_PressTemp_Alarm_Word
0	Circuit A Discharge Pressure Sensor Alarm	11	Circuit B Low-Pressure Switch Alarm	22	
1	Circuit A Discharge Temp Sensor Alarm	12	Circuit A High Sat Discharge Temp Alarm	23	
2	Circuit A Suction Pressure Sensor Alarm	13	Circuit B High Sat Discharge Temp Alarm	24	
3	Circuit A Suction Temp Sensor Alarm	14		25	
4	Circuit B Discharge Pressure Sensor Alarm	15		26	
5	Circuit B Discharge Temp Sensor Alarm	16		27	
6	Circuit B Suction Pressure Sensor Alarm	17		28	
7	Circuit B Suction Temp Sensor Alarm	18		29	
8	Circuit A High-Pressure Switch Alarm	19		30	
9	Circuit A Low-Pressure Switch Alarm	20		31	
10	Circuit B High-Pressure Switch Alarm	21			

Device Offline Word Table (IV-8)					
Bit	Device_Offline_Word	Bit	Device_Offline_Word	Bit	Device_Offline_Word
0	Space T-Stat 1 Offline	11	Expansion Board 4 Alarm	22	
1	Space T-Stat 2 Offline	12		23	
2	Space T-Stat 3 Offline	13		24	
3	Space T-Stat 4 Offline	14		25	
4	VFD Offline Supply Fan	15		26	
5		16		27	Master Unit Offline Alarm
6		17		28	Slave Unit 1 Offline Alarm
7		18		29	Slave Unit 2 Offline Alarm
8	Expansion Board 1 Alarm	19		30	Slave Unit 3 Offline Alarm
9	Expansion Board 2 Alarm	20		31	Slave Unit 4 Offline Alarm
10	Expansion Board 3 Alarm	21			

Device Alarm Word Table (IV-9)					
Bit	Device_Alarm_Word	Bit	Device_Alarm_Word	Bit	Device_Alarm_Word
0	Cold Coil Temperature Sensor Alarm	11	GreenTrol OAD AFMS Alarm	22	Inverter Scroll 1 Alarm
1		12	Return CO2 Sensor Alarm	23	
2	Mixed Temperature Sensor Alarm	13	Return Duct Static Pressure Sensor Alarm	24	EVD Valve A Alarm
3	Supply Duct Static Pressure Sensor Alarm	14	Return Temperature Sensor Alarm	25	
4	Supply Fan AFMS Alarm	15	Return RH Sensor Alarm	26	SF VFD Alarm
5	Supply Air Temp Sensor Alarm	16	Space CO2 Sensor Alarm	27	
6	Exhaust Fan AFMS Alarm	17	Space RH Sensor Alarm	28	
7	Exhaust Temperature Sensor Alarm	18	Space Static Pressure Sensor Alarm	29	
8	Outside Air Temp Sensor Alarm	19	Space Temperature Sensor Alarm	30	
9	Outside RH Sensor Alarm	20	IG Furnace Alarm	31	
10	OAD AMD Alarm	21			

System Word Table (IV-10)					
Bit	System_Word	Bit	System_Word	Bit	System_Word
0	Heat Wheel Enable	11	Drain Pan Alarm	22	BMS Offline Alarm
1	Preheat Enable	12	Freeze Stat Alarm	23	
2	Reversing Valve (Cooling (0)/Heating(1))	13	Filter Alarm	24	
3		14	Space High Static Alarm	25	
4		15	Return Low Static Alarm	26	
5		16	Shutdown Input Alarm	27	
6	Supply Temp Low Limit Alarm	17	Energy Recovery Wheel High Diff Pressure	28	Heat-Cool Only - Dehumidification Request Active
7	Supply Temp High Limit Alarm	18	Energy Recovery Wheel Rotation Alarm	29	Heat-Cool Only - Heating Request Active
8	Supply High Duct Static Alarm	19		30	Heat-Cool Only - Coil Setpoint Alarm Active
9	Supply Fan 1 Alarm	20	Heat Pump Heating Lock Out Alarm	31	Heat-Cool Only - Supply Setpoint Alarm Active
10	Exhaust Fan 1 Alarm	21	Permanent Memory - Too Many Writes		

Unit Status Word Table (IV-11)					
Bit	Unit_Status_Word	Bit	Unit_Status_Word	Bit	Unit_Status_Word
0	Off/Standby	11	Remote Off	22	Dehumidifying
1	Unoccupied Start	12	System Shutdown Alarm	23	Hot Gas Reheat Active
2	Occupied Start	13	Supply Fan Only	24	HGRH Purging
3	Opening Dampers	14	Exhaust Fan Only	25	Dehum w/Heat
4	Dampers Open	15	Purge Mode (Supply and Exhaust Only)	26	Energy Recovery Defrost Active
5	Fan Start Delay	16	Case Heat Active	27	Heat Pump Defrost Active
6	Exhaust Fan On	17	Fans Only	28	Morning Warm Up/Cool Down Active
7	Supply Fan On	18	Economizing	29	Winter Ramp Active
8	System On	19	Energy Recovery Active	30	
9	Soft Shutdown	20	Cooling	31	Overrides Active
10	System Disabled	21	Heating		