

## Installation, Operation and Maintenance Manual

Please read and save these instructions for future reference. Read carefully before attempting to assemble, install, operate or maintain the product described. Protect yourself and others by observing all safety information. Failure to comply with these instructions will result in voiding of the product warranty and may result in personal injury and/or property damage.



### General Safety Information

Only qualified personnel should install and maintain this system. Personnel should have a clear understanding of these instructions and should be aware of general safety precautions. Improper installation can result in electric shock, possible injury due to coming in contact with moving parts, as well as other potential hazards. Other considerations may be required if high winds or seismic activity are present. If more information is needed, contact a licensed professional engineer before moving forward.

1. Follow all local electrical and safety codes, as well as the National Electrical Code (NEC), the National Fire Protection Agency (NFPA), where applicable. Follow the Canadian Electrical Code (CEC) in Canada.
2. All moving parts must be free to rotate without striking or rubbing any stationary objects.
3. Unit must be securely and adequately grounded.
4. Verify that the power source is compatible with the equipment.
5. Never open access doors to the unit while it is running.

#### WARNING

To prevent electrocution, do not puncture the interior or exterior panels of the roof.

#### DANGER

Always disconnect power before working on or near this equipment. Lock and tag the disconnect switch or breaker to prevent accidental power up.

#### CAUTION

This unit is equipped with a compressed refrigerant system. If a leak in the system should occur, immediately evacuate the area. An EPA Certified Technician must be engaged to make repairs or corrections. Refrigerant leaks may also cause bodily harm.

#### CAUTION

When servicing the unit, the internal components may be hot enough to cause pain or injury. Allow time for cooling before servicing.

#### CAUTION

Condensing fans may operate when rooftop ventilator is not operating.

## Table of Contents

Product Overview . . . . .	2
Safety Listing . . . . .	2
Models and Capacities . . . . .	2
Receiving, Handling, Storage . . . . .	3
Installation	
Typical Unit Weights and Dimensions . . . . .	4
Service Clearances . . . . .	4
Minimum Pad Dimensions . . . . .	4
Lifting . . . . .	4
Electrical and Refrigeration Entry Locations . . . . .	5
Piping and Refrigeration Information . . . . .	6-7
Factory-Installed Refrigeration System Components . . . . .	8
Control Center Components . . . . .	9
Controller Overview . . . . .	9
Start-Up Procedure	
Warnings . . . . .	10
Tools Required . . . . .	10
Pre-Start-Up Checklist . . . . .	11
Start-Up Procedure . . . . .	11
Voltage Imbalance . . . . .	11
Start-Up Checklist . . . . .	12
Troubleshooting . . . . .	13
Routine Maintenance	
Semiannually . . . . .	13
Annually . . . . .	13
Coil Maintenance . . . . .	13
Appendix A: Condenser Controller . . . . .	14-15
Maintenance Log . . . . .	Backcover
Our Commitment . . . . .	Backcover

## Product Overview

A remote condensing unit is configured to only be paired with a rooftop ventilator (model RV or RVE). The RV/RVE unit provides stand-alone control for the PDX operation. Remote condensing units have stand alone control of the condensing fans. The condensing fan controller will modulate the lead Electronically Commutated (EC) condensing fan and stage additional fan(s) to maintain head pressure. All units are designed for R410A refrigerant. Do not use tools or parts designed for other refrigerants.

### Safety Listing

Models are ETL Listed.

### Models and Capacities

Model	Cooling Capacity
RC-25/40	5 to 15 tons
RC-45/85	15 to 30 tons



## Receiving

This product may have been subject to road salt during transit. If so, immediately wash off all visible white residue from all exterior surfaces. Upon receiving the product, check to ensure all line items are accounted for by referencing the delivery receipt or packing list. Inspect each crate or carton for shipping damage before accepting delivery. Alert the carrier if any damage is detected, **do not refuse shipment**. The customer shall make notation of damage (or shortage of items) on the delivery receipt and all copies of the bill of lading which should be countersigned by the delivering carrier. If damaged, immediately contact your manufacturer's representative. Any physical damage to the unit after acceptance is not the responsibility of the manufacturer.

## Handling

Units are to be rigged and moved by the lifting brackets provided. Location of brackets varies by model and size. Handle in such a manner as to keep from scratching or chipping the coating. Damaged finish may reduce ability of unit to resist corrosion.

## Unpacking

Verify that all required parts and the correct quantity of each item have been received. If any items are missing, report shortages to your local representative to arrange for obtaining missing parts. Sometimes it is not possible that all items for the unit be shipped together due to availability of transportation and truck space. Confirmation of shipment(s) must be limited to only items on the bill of lading.

## Storage

Units are protected against damage during shipment. If the unit cannot be installed and operated immediately, precautions need to be taken to prevent deterioration of the unit during storage. The user assumes responsibility of the unit and accessories while in storage. The manufacturer will not be responsible for damage during storage.

These suggestions are provided solely as a convenience to the user.

The ideal environment for the storage of units and accessories is indoors, above grade, in a low humidity atmosphere which is sealed to prevent the entry of blowing dust, rain, or snow. Units designed for outdoor applications may be stored outdoors. All accessories must be stored indoors in a clean, dry atmosphere.

## Indoor

Maintain temperatures evenly to prevent condensation. Remove any accumulations of dirt, water, ice, or snow and wipe dry before moving to indoor storage. To avoid condensation, allow cold parts to reach room temperature. Leave coverings loose to permit air circulation and to allow for periodic inspection.

The unit should be stored at least 3½ in. (89 mm) off the floor. Clearance should be provided to permit air circulation and space for inspection.

## Outdoor

The unit should be placed on a level surface to prevent water from leaking into the unit. The unit should be elevated so that it is above water and snow levels. Ensure sufficient support to prevent unit from settling into soft ground. Locate parts far enough apart to permit air circulation, sunlight, and space for periodic inspection. To minimize water accumulation, place all unit parts on blocking supports so that rain water will run off.

Do not cover parts with plastic film or tarps as these cause condensation of moisture from the air passing through heating and cooling cycles.

## Inspection and Maintenance

While in storage, inspect units once per month. Keep a record of inspection and maintenance performed.

If moisture or dirt accumulations are found on parts, the source should be located and eliminated. At each inspection, rotate the fan wheel by hand ten to fifteen revolutions to distribute lubricant on motor. If paint deterioration begins, consideration should be given to touch-up or repainting. Units with special coatings may require special techniques for touch-up or repair.

Machined parts coated with rust preventive should be restored to good condition promptly if signs of rust occur. Immediately remove the original rust preventive coating with petroleum solvent and clean with lint-free cloths. Polish any remaining rust from surface with crocus cloth or fine emery paper and oil. Do not destroy the continuity of the surfaces. Wipe thoroughly clean with Tectyl® 506 (Ashland Inc.) or the equivalent. For hard to reach internal surfaces or for occasional use, consider using Tectyl® 511M Rust Preventive, WD-40® or the equivalent.

## Removing from Storage

As units are removed from storage to be installed in their final location, they should be protected and maintained in a similar fashion until the equipment goes into operation.

Prior to installing the unit and system components, inspect the unit assembly to make sure it is in working order.

1. Check all fasteners, set screws on the fan, wheel, bearings, drive, motor base, and accessories for tightness.
2. Rotate the fan wheel(s) by hand and assure no parts are rubbing.

# Installation

## Typical Unit Weights and Dimensions

Unit Size	L	W	H	Unit Weight (lbs.)
RC-25/40	115	46	67	815
RC-45/85	121	50	71	905

All dimensions are shown in inches.

## Service Clearances

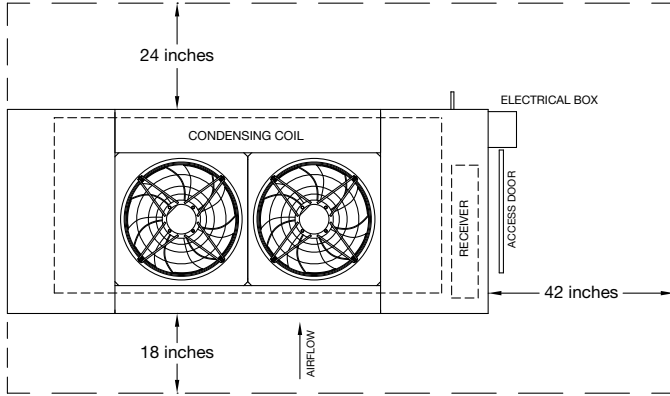

A minimum of 48 inches above the condenser fans is acceptable, but unobstructed is strongly recommended.

## Minimum Pad Dimensions

Unit Size	A	B
RC-25/40	120	50
RC-45/85	125	54

All dimensions are shown in inches.

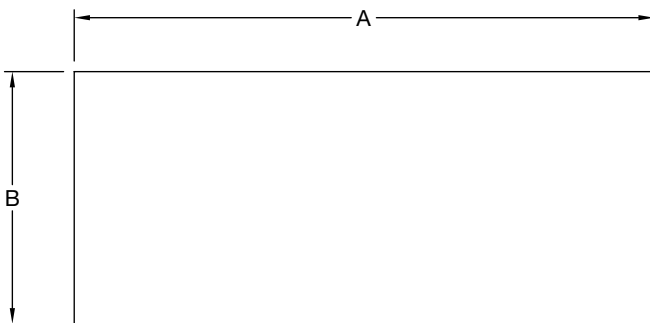

## Lifting

### WARNING

Spreader bars are required to prevent damage to the cabinet, failure to do so can result in damage that is the installer's responsibility.

1. Preparation of mounting location should be completed prior to lifting unit.
2. Before lifting, be sure that all shipping materials have been removed from unit.
3. To assist in determining rigging requirements, weights are provided in the Installation, Unit Typical Unit Weights and Dimensions section of this manual.
4. Unit must be lifted by all lifting lugs provided at top of unit.
5. Spreader bars must span the unit to prevent damage to the cabinet by the lift cables.

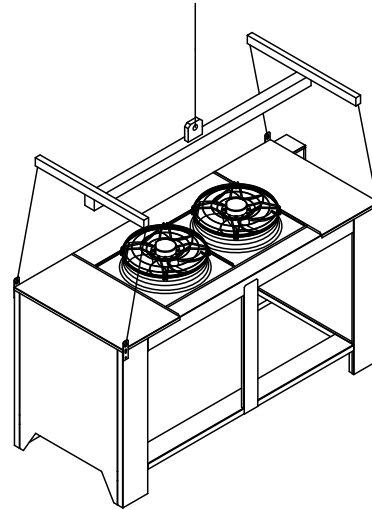

6. Always test-lift the unit to check for proper balance and rigging before hoisting to desired location.
7. Never lift units in windy conditions.

# Electrical and Refrigerant Entry Locations

Manufacturer recommends the electrical service be brought into the control center cabinet through the bottom, as shown.

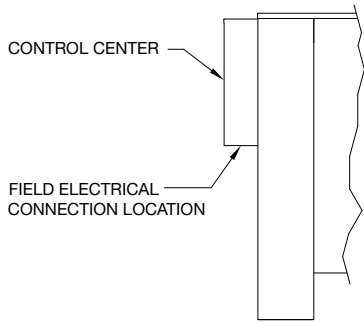

## Piping Locations RC-112

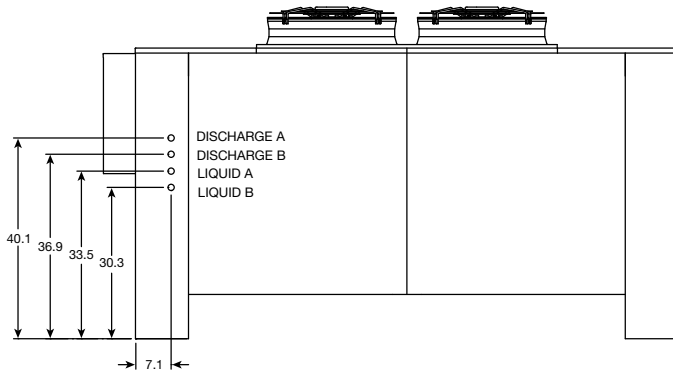

All dimensions shown are in inches.

## Piping Locations RC-212

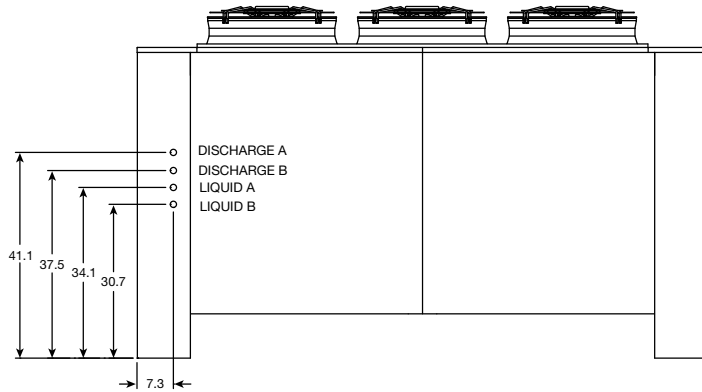

All dimensions shown are in inches.

# Piping and Refrigeration Information

Both the remote condenser and the associated units are shipped with a nitrogen holding charge of at least 5 psig. **Relieve pressure prior to working on unit.**

Piping should be in accordance with accepted industry standards. Pipe work should be supported independently of the coils. Undue stress should not be applied at the connection to coil headers. Manufacturer is not responsible for interconnecting piping.

Refrigerant lines shall be sized based on the Recommended Line Sizes table. Consult the factory before changing line sizes. The vertical rise between the unit and condensing unit must be less than 25 feet. The maximum equivalent length of piping is 100 feet. Equivalent length must account for the combined length of piping, elbows and fittings. Equivalent line lengths of common elbows are shown in the Equivalent Lines Lengths table.

## Piping Procedure

1. Relieve nitrogen holding charge. If this charge is not present, check the system for leaks.
2. Run interconnecting piping between main unit and condensing unit. Discharge line piping to be pitched in the direction of flow (1/2-inch per 10 feet of horizontal piping). Interconnected piping should be sized according to the Recommended Line Sizes table.
3. Braze all connections under nitrogen purge.
4. When the unit is located at a lower elevation than the condenser and the piping rise is over 20 feet, an oil drip leg must be field provided and installed at the bottom of the first rise in the discharge line. Install drip legs at the bottom of each rise over 10 feet.
5. The discharge line must be insulated for safety due to high piping temperatures.
6. The liquid line must be insulated if routed through areas where the temperatures are above the design outdoor air temperature to avoid a reduction in subcooling.
7. The system must be pressure checked with a nitrogen charge of 475 psig. Hot gas reheat (optional) to be at 100% during pressure check. System must hold 475 psig for at least 30 minutes.
8. The system must be evacuated to 500 microns or less. Hot gas reheat (optional) to be at 100% during evacuation. The pressure may increase a small amount, but must stabilize at a pressure below 500 microns.
9. Charge the system to 10-12°F subcooling and adjust thermal expansion valve to maintain 7-9°F superheat. (Approximate charges are listed in the Approximate Charge table). Subcooling must be measured at the inlet of the expansion valve. Superheat must be measured at the outlet of the DX coil. Unit must be charged with the

compressor(s) at 100% at the highest ambient possible. Hot gas reheat (optional) to be at 0% during charging.

10. If the unit has hot gas reheat, cycle hot gas reheat valve to 100% for 5 minutes and then back to 0% and recharge the system to 10°F-12°F subcooling and adjust thermal expansion valve to maintain 7°F-9°F superheat.
11. Additional oil may be needed dependent on interconnecting piping length. If the system contains more than 20 lbs. of refrigerant, an ounce of oil should be added for every 5 lbs. of refrigerant over 20 lbs. Use POE oil only.

## Recommended Line Sizes

Tonnage	Number of Circuits	Liquid Line		Discharge Line	
		Over 50 ft.	Under 50 ft.	Over 50 ft.	Under 50 ft.
RC-25/40	5	1/2		5/8	
	7.5	5/8		3/4	
	10	1/2		5/8	
	12.5	1/2		3/4	5/8
	15	5/8		3/4	
RC-45/85	15	5/8		3/4	
	17.5	5/8		3/4	
	20	5/8		7/8	3/4
	25	3/4		7/8	3/4
	30	3/4		7/8	3/4

All line sizes shown in inches.

## Equivalent Line Lengths

Line Size	Elbows		Tees
	90° Long Radius	45° Standard	Flow Through Branch
1/2	1	0.8	3
5/8	1.2	0.85	3.5
3/4	1.4	0.9	4
7/8	1.6	1.1	4.5

All equivalent lengths shown in feet.



## Piping and Refrigeration Information - *continued*

### Approximate Charge

Tonnage		Units with HGRH		Units without HGRH		Refrigerant Add/ Ft of Line	
		Circuit A (lbs.)	Circuit B (lbs.)	Circuit A (lbs.)	Circuit B (lbs.)	Circuit A (oz.)	Circuit B (oz.)
RC-25/40	5	23.0	-	20.6	-	1.1	-
	7.5	24.0	-	21.6	-	1.8	-
	10	13.4	10.6	11.0	10.6	1.1	1.1
	12.5	14.6	11.8	12.2	11.8	1.1	1.1
	15	18.3	15.5	15.9	15.5	1.8	1.8
RC-45/85	15	22.5	14.3	14.7	14.3	1.8	1.8
	17.5	22.5	14.3	14.7	14.3	1.8	1.8
	20	29.0	21.2	21.2	21.2	1.8	1.8
	25	29.0	21.2	21.2	21.2	2.6	2.6
	30	30.8	23.3	23.0	23.3	2.6	2.6

# Factory-Installed Refrigeration System Components

## Split DX Cooling with Three-Way Hot Gas Reheat and Hot Gas Bypass

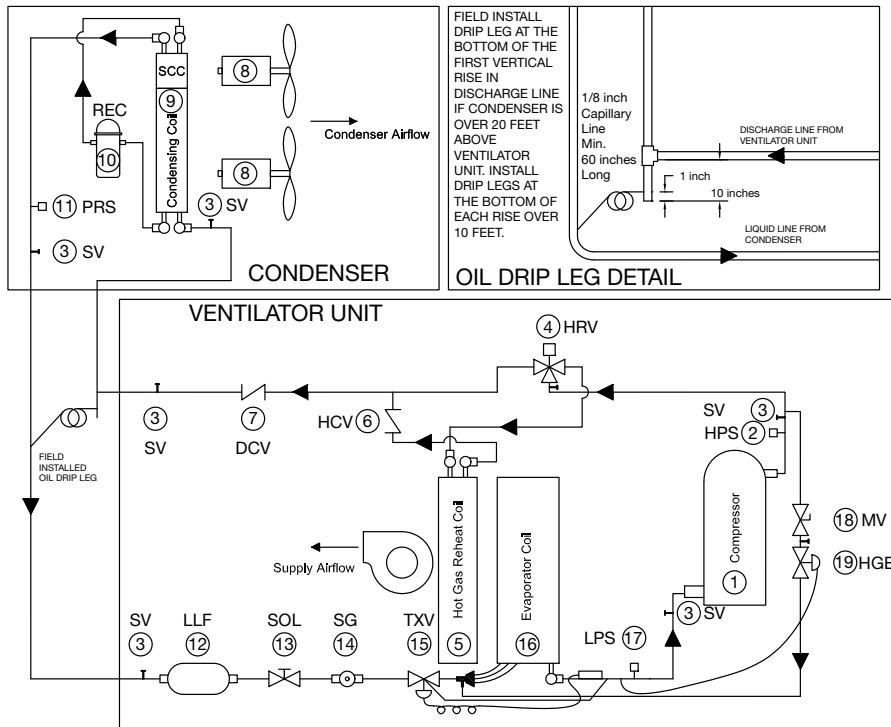

### 1. Compressor

### 2. High Limit Pressure Switch

The switch opens when refrigerant pressure increases above the set point in the discharge line. A manual reset is then required.

### 3. Service Access Ports

### 4. Hot Gas Reheat Valve (optional)

Units equipped with a reheat coil use a three-way valve with actuator to control the supply air discharge temperature of the unit during dehumidification mode. The unit controller provides a 0-10 VDC signal to control the amount of reheat to meet the supply temperature set point.

### 5. Hot Gas Reheat Coil (Optional)

### 6. Hot Gas Reheat Check Valve (Optional)

### 7. Discharge Line Check Valve

### 8. Condenser Fans

### 9. Condensing Coil

### 10. Liquid Receiver (Optional)

### 11. Pressure Sensor

### 12. Liquid Line Filter Drier

### 13. Liquid Line Solenoid Valve/Coil

### 14. Sight Glass

### 15. Thermostatic Expansion Valve (TXV)

Each unit is equipped with a TXV on each refrigerant circuit. The valve controls the flow of liquid refrigerant entering the evaporator coil by maintaining a constant, factory-set superheat of 10°F. The valve is adjustable and is located on the side of the evaporator coil and can be accessed through the coil access panel.

### 16. Evaporator Coil

### 17. Low Limit Pressure Switch

The switch is installed on the suction line and disables the DX system when the suction pressure drops below the set point. The switch will auto reset when the pressure rises above the auto-reset set point.

### 18. Hot Gas Bypass Manual Shut Off Valve (Optional)

Used to disable hot gas bypass for service and troubleshooting procedures.

### 19. Hot Gas Bypass Valve (Optional)

On units equipped with hot gas bypass, hot gas from the compressor is injected into the liquid line of the evaporator coil after the TXV.

**Valve Adjustment** - To adjust the valve, connect a pressure gauge to the suction line and block the entering air to the evaporator coil. The valve should begin to open when the suction pressure drops to approximately 115 psig for R-410A (the valve will feel warm to the touch). Adjustments are made by first removing the cap on the bottom of the valve and then turning the adjusting stem clockwise to increase the setting pressure (counterclockwise to decrease). Allow several minutes between adjustments for the system to stabilize. When adjustment is complete, replace the cap on the valve.



# Control Center Components

## Main Control Center Components

Represents a typical installation for remote condenser.

### Low Voltage Side

1. Head pressure control  
(see Appendix A: Condenser Controller)
2. Low voltage terminal strip

### High Voltage Side

3. Condenser fan motor contractors
4. Unit disconnect
5. Transformer

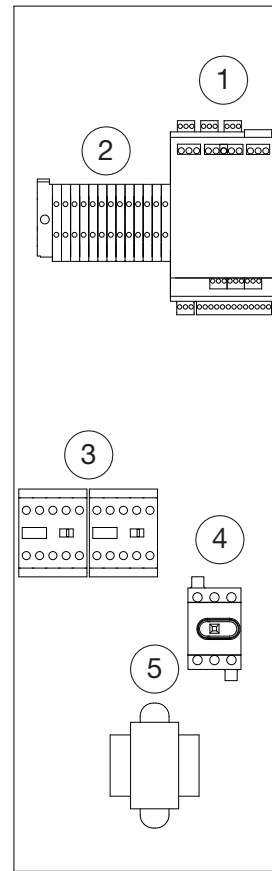

## Controller Overview

See Appendix A: Condenser Controller on pages 14-15

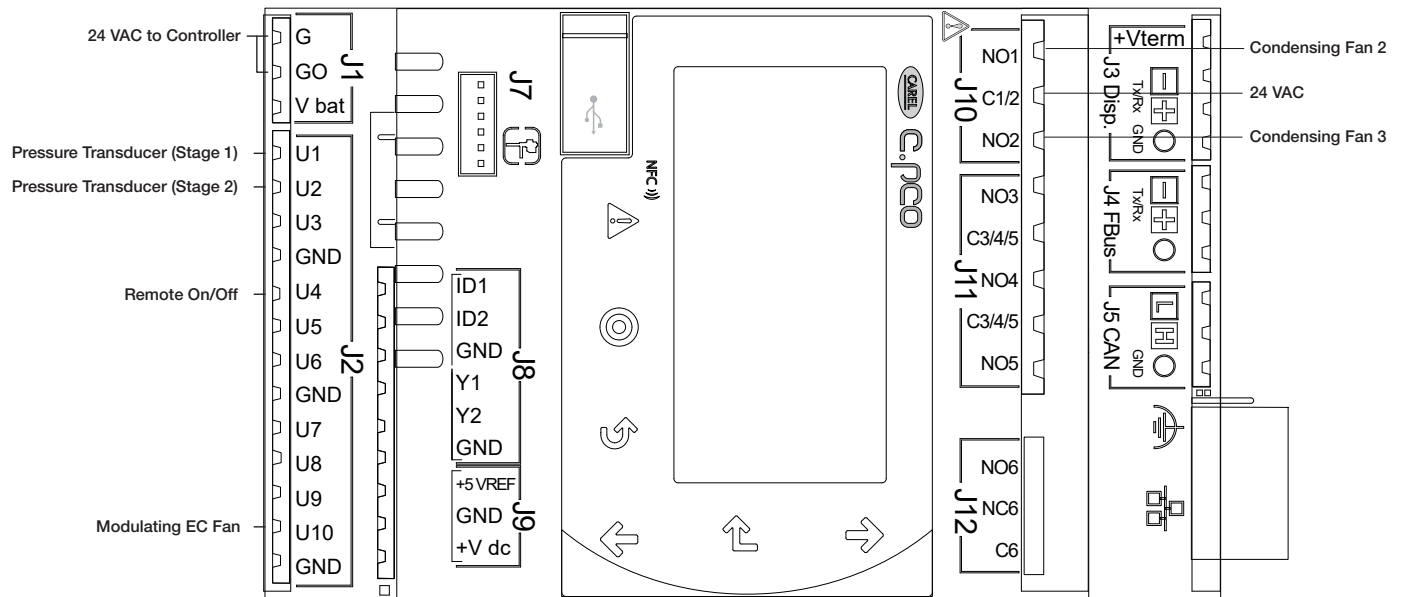

## Start-Up Procedure

### DANGER

Electric shock hazard. Can cause injury or death. Before attempting to perform any service or maintenance, turn the electrical power to unit to OFF at disconnect switch(es). Unit may have multiple power supplies.

### CAUTION

Use caution when removing access panels or other unit components, especially while standing on a ladder or other potentially unsteady base. Access panels and unit components can be heavy and serious injury may occur.

### CAUTION

Do not run unit during construction phase. Damage to internal components may result and void warranty.

### WARNING

- Unit was factory tested. All fans are set-up to run correctly when supplied power. If any one fan is running backwards immediately turn off the power. Switch two leads on the incoming power to the disconnect. This will ensure proper operation of the unit.
- Do not jumper any safety devices when operating the unit. This may damage components within or cause serious injury or death.
- DX system is charged with refrigerant. Start-up must be performed by EPA Certified Technician.

### SPECIAL TOOLS REQUIRED

- Voltage Meter (with wire probes)
- Amperage Meter
- Pressure Gauges – refrigerant
- Tachometer
- Thermometer

Every installation requires a comprehensive start-up to ensure proper operation of the unit. As part of that process, the following checklist must be completed and information recorded. Starting up the unit in accordance with this checklist will not only ensure proper operation, but will also provide valuable information to personnel performing future maintenance. Should an issue arise which requires factory assistance, this completed document will allow unit experts to provide quicker resolve. Qualified personnel should perform start-up to ensure safe and proper practices are followed.

Unit Model No. \_\_\_\_\_

Unit Serial No. \_\_\_\_\_

Compressor 1 Model No. \_\_\_\_\_

Compressor 1 Serial No. \_\_\_\_\_

Compressor 2 Model No. \_\_\_\_\_

Compressor 2 Serial No. \_\_\_\_\_

RC Model No. \_\_\_\_\_

RC Serial No. \_\_\_\_\_

Start-Up Date \_\_\_\_\_

Start-Up Personnel Name \_\_\_\_\_

Start-Up Company \_\_\_\_\_

Phone Number \_\_\_\_\_

## Start-Up Procedure - *continued*

---

### Pre-Start-Up Checklist

- Disconnect and lock-out and tag all power switches.
- Check condensing fans for any damage or misalignment. Spin the blades to ensure they are free turning without any resistance and are not coming in contact with any parts.
- Check the tightness of all factory wiring connections.
- Check for proper mounting.
- Look over the piping system.
- Inspect condensing coil. Fins may get damaged in transit or during construction. Carefully straighten fins with a fin comb.

### Start-Up Procedure

The unit will be in operational mode during start-up. Use necessary precautions to avoid injury. All data for the Start-Up Checklist must be collected while the unit is running.

- Make sure the Pre-Start-Up checklist is complete.
- Turn the disconnect on. Make sure all fans are rotating in the correct direction. The condensing fans will stage on based on pressure.

### Voltage Imbalance

In a 3-phase system, excessive voltage imbalance between phases will cause motors to overheat and eventually fail. Maximum allowable imbalance is 2%. To determine voltage imbalance, use recorded voltage measurements in this formula.

Key:            V1, V2, V3 = line voltages as measured  
VA (average) =  $(V1 + V2 + V3) / 3$   
VD = Line voltage (V1, V2 or V3) that deviates farthest from average (VA)

Formula:      % Voltage Imbalance =  $[100 \times (VA - VD)] / VA$

# Start-Up Checklist

SERIAL NUMBER: \_\_\_\_\_

## Condenser Line Voltage. Check at unit disconnect.

L1-L2 \_\_\_\_\_ Volts      L2-L3 \_\_\_\_\_ Volts      L1-L3 \_\_\_\_\_ Volts

## Rooftop Unit Line Voltage. Check at unit disconnect.

L1-L2 \_\_\_\_\_ Volts      L2-L3 \_\_\_\_\_ Volts      L1-L3 \_\_\_\_\_ Volts

## Motor Amp Draw

Supply Motor 1 Amps	L1 _____ Amps	L2 _____ Amps	L3 _____ Amps
Exhaust Motor 1 Amps	L1 _____ Amps	L2 _____ Amps	L3 _____ Amps

## Energy Wheel Motor

L1 \_\_\_\_\_ Amps      L2 \_\_\_\_\_ Amps      L3 \_\_\_\_\_ Amps

## Condenser

Total Equivalent Piping Length	_____ Feet	Evacuation	_____ Microns
Equivalent Length of Elbows and Fittings	_____ Feet	Total Refrigerant Charge	_____ Lbs.
Piping Length	_____ Feet	Oil Added	_____ Oz.
Piping Rise	_____ Feet	Oil Drip Installed	Yes / No
Pressure Check	_____ PSI		

## Condensing Fans

Condensing Fan 1	L1 _____ Amps	L2 _____ Amps	L3 _____ Amps
Condensing Fan 2	L1 _____ Amps	L2 _____ Amps	L3 _____ Amps
Condensing Fan 3 (Opt)	L1 _____ Amps	L2 _____ Amps	L3 _____ Amps

## Compressors

Outdoor Air Temperature	_____ Deg F	Outdoor Air Relative Humidity	_____ % RH
Return Air Temperature	_____ Deg F	Return Air Relative Humidity	_____ % RH

### Compressor 1

### Compressor 2

L1	_____ Amps	_____ Amps
L2	_____ Amps	_____ Amps
L3	_____ Amps	_____ Amps
<b>Crankcase Heater</b>	_____ Amps	_____ Amps
<b>Superheat</b> (should be between 7° and 9°F)	_____ Deg. F	_____ Deg. F
<b>Subcooling</b> (should be between 10° and 12°F)	_____ Deg. F	_____ Deg. F
<b>Discharge Pressure</b> (should be between 300 and 500 PSIG)	_____ PSIG	_____ PSIG
<b>Suction Line Pressure</b> (should be between 100 and 135 PSIG)	_____ PSIG	_____ PSIG
<b>Liquid Line Temperature</b>	_____ Deg. F	_____ Deg. F
<b>Liquid Line Pressure</b>	_____ PSIG	_____ PSIG
<b>Suction Line Temperature</b>	_____ Deg. F	_____ Deg. F
<b>Moisture Indicating Sight Glass: Liquid Visible</b>	Yes / No	Yes / No
<b>Moisture Indicating Sight Glass: Color of Center Dot</b>	Purple / Pink	Purple / Pink
<b>Hot Gas Bypass Operational</b>	Yes / No	NA



## Troubleshooting

Symptom	Possible Cause	Corrective Action
Motor over amps	Motor voltage incorrect	Check motor wiring. Check motor nameplate versus supplied voltage.
	Shorted windings in motor	Replace motor.
Condensing fan not operating	Low pressure in system	Check pressure in system.
	Condensing fan relay not pulling in.	Possible cause: Head pressure is low enough to only operate lead condensing fan. Connect gauges and verify pressure. Check coil voltage. Check relay for bent pin. Replace.
	Condenser fan motor defective.	Check fan motor.
Controller resets itself or is not on.	Check the supply voltage to the controller at terminals G-G0. The board requires 24VAC.	Check the 24VAC transformer in the control center.

## Routine Maintenance

### DANGER

Electric shock hazard. Can cause injury or death. Before attempting to perform any service or maintenance, turn the electrical power to the unit to OFF at disconnect switch(es). Unit may have multiple power supplies.

### CAUTION

Use caution when removing access panels or other unit components, especially while standing on a ladder or other potentially unsteady base. Access panels and unit components can be heavy and serious injury may occur.

This unit requires minimal maintenance to operate properly. Maintenance requirements for this model vary for each installation and depend greatly on how much the system is used and the cleanliness of the air. Proper maintenance will increase the life of the system and maintain its efficiency. Maintenance must be performed by experienced technicians and in the case of refrigeration systems, must be done by an EPA Certified Technician.

Maintenance frequency is based on a presumed nominal use of the system. If the system is being run constantly, the frequency should be adjusted accordingly. If there is seasonal debris in the air which can be drawn into the filters and the coils, they should be checked more frequently. If the system is being used for only a few hours per day, the frequency may be reduced. Use the Maintenance Log at the end of this manual to record each maintenance session and observations and then establish a maintenance schedule that is appropriate for the installation.

### Maintenance Frequency: Semiannually

It is recommended that the annual inspection and maintenance occur at the start of the cooling season. After completing the checklist, follow the unit start-up checklist provided in the manual to ensure the refrigeration system operates in the intended manner.

#### 1. Condensing Coils

Inspect for cleanliness – clean as required

#### 2. Condensing Fan Blades and Motors

Inspect for cleanliness

Check all fasteners for tightness

Check for fatigue, corrosion and wear

### Annually

#### 1. Wiring Connections

Check all connections for tightness

#### 2. Cabinet

Check entire cabinet, inside and out, for dirt buildup or corrosion. Remove accumulated dirt, remove any surface corrosion and coat the area with appropriate finish.

### Maintenance Procedures:

**Coil Maintenance** - Coils must be cleaned to maintain maximum performance. Check coils once per year under normal operating conditions and if dirty, brush or vacuum clean. Soiled fins reduce the capacity of the coil, demand more energy from the fan and create an environment for odor and bacteria to grow and spread through the conditioned zone.

For coils with fragile fins or high fin density, foaming chemical sprays and washes are available. Many coil cleaners use harsh chemicals, so they must be used with caution by qualified personnel only. Care must be taken not to damage the coils, including the fins, while cleaning. **Caution: Fin edges are sharp!**

## Appendix A: Condenser Controller

**RC v1.03**

**Revision Date: 11/30/2021**

The condenser controller offers improved control of the condenser pressure by modulating the lead condensing fan and staging the additional condensing fan(s).

### Sequence of Operation

The condensing fans will be controlled to maintain the head pressure set point based on the highest circuit pressure.

As the head pressure approaches the set point (325 psig) from the lower side, the lead condensing fan will ramp up. Once the lead condensing fan has reached 100%, the next available condensing fan will be staged

on and the lead condensing fan will ramp down. If the lead condensing fan reaches 100% after the second fan is on, the third condensing fan (optional) will stage on.

As the head pressure approaches the set point (325 psig) from the high side, the lead condensing fan will begin to ramp down. Once the lead condensing fan has reached minimum speed, the third condensing fan (optional) will be staged off and the lead condensing fan will ramp up. If the lead condensing fan reaches minimum speed after the third condensing fan is off, the second condensing fan will stage off.



### Display Use

The condenser controller is located on the control panel of the condenser. The face of the controller has six keys, allowing the user to view condenser conditions and alter parameters. The condenser controller is pre-programmed with easy to use menus. To change the display contrast, hold the Enter and Escape button while pressing the Up and Down arrows.

#### Keypad Description

Keypad Description		
	Alarm	Button will blink red, indicating an alarm condition. Press to review current alarms. To review previous alarms, access the DATA LOGGER through the main menu.
	Down Arrow	The arrow keys allow the user to scroll through different screens and adjust parameters.
	Up Arrow	
	Enter	A. In screens with adjustable parameters, pressing the Enter key moves the cursor from the upper left corner of the screen to the parameter. The arrow keys can then be used to adjust the parameter. B. To move to the next parameter on the same screen, press the Enter button. C. To save the change, press the Enter button until the cursor moves back to the upper left corner of the screen.
	Escape	Allows the user to exit the current menu, jumping to the Main Menu.
	Program	Pressing the Prg (Program) button allows the user to enter the Main Program Menu.

#### Main Menu Overview

The condenser controller will revert to the default main menu screen. This screen includes basic information on the configuration of the controller as well as a series of shortcuts in the bottom right corner. The shortcuts include Monitoring Menu “Monitor”, Setpoint menu “Set”, Info Menu “Info” and Condenser On/Off “On/Off”. Scroll through the shortcuts by using the Up and Down keys. Enter the menu by pressing the Enter key.

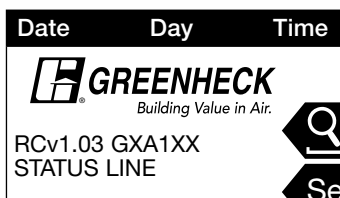

**THE INITIAL MENU SCREEN DISPLAYS THE PROGRAM VERSION, CONFIGURATION CODE AND STATUS LINE. THE STATUS LINE DISPLAYS WHICH MODE THE CONDENSER IS IN.**

Possible modes include:

- Off by Keypad
- Condenser On
- Remote Off
- Active Alarm
- Override Enabled

Note: Scroll up and down on the main menu to access quick menu options. Options include: monitoring, set point, information and on/off.

## A. On/Off

The **On/Off** menu allows the user to view the detailed On/Off status of the controller.

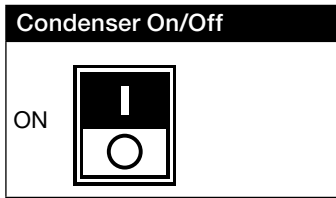

The condenser ships from the factory in a disabled state. To allow the condenser to operate, the condenser must be enabled in the condenser On/Off menu.

**Actual State:** The controller may be in following On/Off states:

- a. Condenser On
- b. Off by Keypad
- c. Remote Off

**Change to (Switch Off/Switch On):** Enables the user manually turn the condenser On/Off via display.

Note: Unit terminal **R and G** must be jumpered in order to enable the condenser.

## B. Monitor

The **Monitor** menu allows the user to view the current status of the unit.

Date	Day	Time
Pressure Control Loop: 100%		
Circuit 1:		325.0 psig
Circuit 2:		325.0 psig
EC Fan Speed:		100%
Fan 2 Enabled:		YES
Fan 3 Enabled:		YES

*THE STATUS SCREEN DISPLAYS REAL TIME CONDITIONS FROM THE SENSORS LOCATED IN THE UNIT.*

## C. Setpoint

The **Setpoint** menu allows the user to view and adjust parameters.

Pressure Set Point	
Active Setpt:	325 psig
System Pressure:	325.0 psig
Source: Local	325 psig
Min:	275 psig
Max:	400 psig

*THIS SCREEN DISPLAYS THE ACTIVE PRESSURE SET POINT.*

When operating, the controller will control the condensing fans to maintain the active pressure set point

## D. Information

The **Information** menu allows the user to view the current program in the controller.

Info	
Greenheck Fan	
Remote Condenser	
Code:	GXA1XX
Ver: 1.03	MM/DD/YY
OS Ver:	4.8.003
Cor Ver:	001
Manual/IOM:	913836

*THE INFORMATION MENU ALLOWS THE USER TO VIEW ALL PERTINENT INFORMATION ON THE CURRENT PROGRAM THAT IS IN THE CONTROLLER.*

**Code:** The controller setup code determines functionality of program. When contacting the factory, please reference this code.

**Ver:** Displays the current program version and data code of the current program.

**Manual:** The manufacturer part number for the corresponding Installation, Operation and Maintenance (IOM) Manual.

**OS:** Indicates to the user which Operating System/Firmware has been installed on the controller.

Info	
System Info	
Board type:	c.p CO mini
Board size:	Basic
Board temp:	0°C
Ret mem writers:	81533
Main task:	
15 ms	66.7cycle/s

Info	
Condenser Hours	
EC Fan:	000000h
AC Fan 1:	000000h
AC Fan 2:	000000h

Info	
Blackout info	
Current time:	
27/08/15	13:46:39
Power Off time:	2.5.01
27/08/15	13:03:13
Length last time off:	
0Days 0Hrs 0min	

# Maintenance Log

Date \_\_\_\_\_ Time \_\_\_\_\_ AM/PM

Notes: \_\_\_\_\_

\_\_\_\_\_

\_\_\_\_\_

\_\_\_\_\_

\_\_\_\_\_

Date \_\_\_\_\_ Time \_\_\_\_\_ AM/PM

Notes: \_\_\_\_\_

\_\_\_\_\_

\_\_\_\_\_

\_\_\_\_\_

\_\_\_\_\_

Date \_\_\_\_\_ Time \_\_\_\_\_ AM/PM

Notes: \_\_\_\_\_

\_\_\_\_\_

\_\_\_\_\_

\_\_\_\_\_

\_\_\_\_\_

Date \_\_\_\_\_ Time \_\_\_\_\_ AM/PM

Notes: \_\_\_\_\_

\_\_\_\_\_

\_\_\_\_\_

\_\_\_\_\_

\_\_\_\_\_

Date \_\_\_\_\_ Time \_\_\_\_\_ AM/PM

Notes: \_\_\_\_\_

\_\_\_\_\_

\_\_\_\_\_

\_\_\_\_\_

\_\_\_\_\_

Date \_\_\_\_\_ Time \_\_\_\_\_ AM/PM

Notes: \_\_\_\_\_

\_\_\_\_\_

\_\_\_\_\_

\_\_\_\_\_

\_\_\_\_\_

Date \_\_\_\_\_ Time \_\_\_\_\_ AM/PM

Notes: \_\_\_\_\_

\_\_\_\_\_

\_\_\_\_\_

\_\_\_\_\_

\_\_\_\_\_

Date \_\_\_\_\_ Time \_\_\_\_\_ AM/PM

Notes: \_\_\_\_\_

\_\_\_\_\_

\_\_\_\_\_

\_\_\_\_\_

\_\_\_\_\_

## Our Commitment

*As a result of our commitment to continuous improvement, Greenheck reserves the right to change specifications without notice.*

Product warranties can be found online at [Greenheck.com](http://Greenheck.com), either on the specific product page or in the literature section of the website at [Greenheck.com/Resources/Library/Literature](http://Greenheck.com/Resources/Library/Literature).

Greenheck's Model RV and RVE catalog and Installation, Operation, and Maintenance Manual provides additional information describing the equipment, fan performance, available accessories, and specification data.

AMCA Publication 410-96, Safety Practices for Users and Installers of Industrial and Commercial Fans, provides additional safety information. This publication can be obtained from AMCA International, Inc. at [www.amca.org](http://www.amca.org).

