

Make-Up Air Systems



Model DG and DGX Direct Gas-Fired

The DG and DGX are designed to provide heated make-up air for industrial, commercial and kitchen applications. The direct gas-fired burner provides a 92% efficient heating system. Installation may be stand-alone or as a combination package with exhaust fan on a common curb.

Quick Build Performance

Capacities range from 800 to 48,000 cfm with up to 4 in. wg static pressure. Heating capacity up to 4,800,000 Btu/hr available.

Optional Evaporative Cooling

The evaporative cooling section includes a galvanized steel housing with a louvered intake, 2-inch aluminum mesh filters and a stainless steel evaporative cooling module. The CELdek® evaporative cooling media has a depth of 12 inches for 90% cooling effectiveness.

Optional Packaged Direct Expansion (PDX) - DGX only

The packaged DX cooling option is designed to cool the kitchen make-up air to a 70-75°F supply air condition to improve space comfort and enhance employee productivity at an economical first cost. The PDX option includes integral low sound condenser fans, condenser and evaporator coils, thermal expansion valves, and compressors.

Model Housing Size	Best Available Program
DG-10 -20 -30	5 Days
DGX-12 -22 -32	10 Days
*DGX with PDX-12 -22 -32	15 Days

**Best Available based on housing size, capacity, coils, and unit accessories.*

Standard Construction	DG	DGX
Galvanized steel unit construction (G90)	■	■
Control center with starter and disconnect	■	■
Vibration isolation	■	■
Factory-wired and tested	■	■
Options and Accessories	DG	DGX
Forward-curved blower	■	■
Backward-curved blower		■
V-bank filters	■	■
Birdscreen weatherhood	■	■
Aluminum mesh filtered weatherhood	■	■
Louvered weatherhood	■	■
Thru-wall installation		■
100% outdoor air, constant volume	■	■
80/20 recirculation		■
Variable air volume (VFD or EC motor)	■	■
Room temperature control	■	■
Discharge temperature control with optional room override	■	■
Burner modulation through an external DDC signal		■
Network interface		■
Remote panel	■	■
Evaporative cooling	■	■
Packaged direct expansion (PDX)		■
Outdoor air damper, inlet	■	■
Discharge damper, outlet	■	■
Duct liner insulation	■	■
Double-wall construction	■	■
Exhaust fan starter	■	■
Dirty filter sensor	■	■
Freeze protection	■	■
Inlet air sensor, mild weather stat	■	■
Variable frequency drive (VFD)	■	■
Service receptacle		■
Auxiliary contacts	■	■
External gas pressure regulator	■	■
Roof curb	■	■
Duct adapter	■	■

Combination Packages

The Greenheck combination kitchen package simplifies installation and reduces field labor costs. The pre-engineered design ensures that the supply fan, exhaust fan, curb and combination extension components interface properly.

Equally important, Greenheck combination packages are specifically designed to comply with NFPA 96.

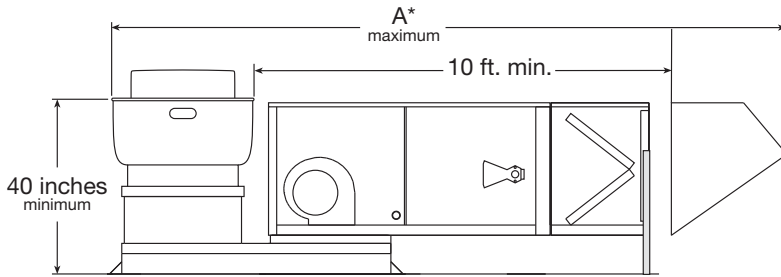

Combination Package - Arrangement DBC

Model	Housing Size	Arrangement DBC	
		A*	Width
DG	H10	185.7	35.5
	H20	204.8	50.0
	H30	227.0	58.8
DGX	H12	178.5	35.4
	H22	243.4	50.0
	H32	268.9	65.1

All dimensions are in inches and include a weatherhood and 2-inch filter section.

*Based on largest available CUBE exhaust fan.

Stand-Alone Arrangements

The DG and DGX are available for either downblast (Arrangement DB) or horizontal (Arrangement HZ) discharge. An upblast discharge (Arrangement UB), left discharge (Arrangement LT) and/or right discharge (Arrangement RL) are also available on the DGX.

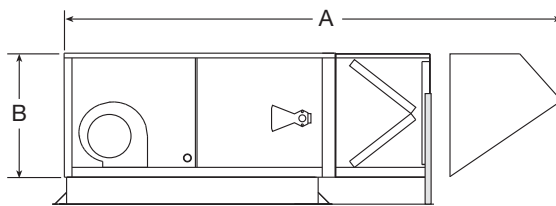

Downblast Discharge - Arrangement DB

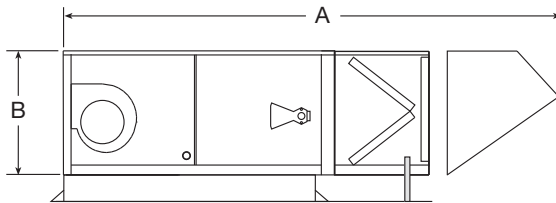

Horizontal Discharge - Arrangement HZ

Model	Housing Size	Arrangement DB/HZ		
		A	B	Width
DG	H10	132.3	33.8	28.0
	H20	148.8	33.8	37.0
	H30	162.9	42.5	48.0
DGX	H12	131.5	39.0	33.7
	H22	174.2	44.9	44.1
	H32	191.5	48.7	53.1

All dimensions are in inches and include a weatherhood and 2-inch filter section.

Thru-Wall Installation DGX

The DGX is available with a pre-engineered, thru-wall installation option, which is ideal when roof penetration is not desirable.

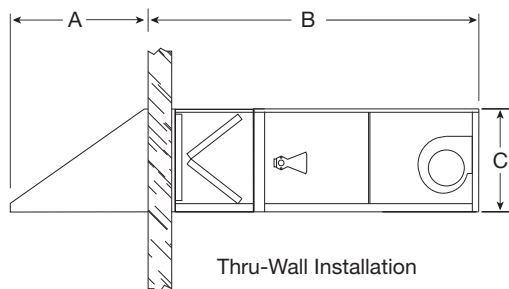

Thru-Wall Installation

Model	Housing Size	Thru-Wall Mount			Width
		A	B	C	
DGX	H12	28.0	122	39	33.7
	H22	41.8	145	44.9	44.1
	H32	63.1	160	48.7	53.1

All dimensions are in inches.

Thru-Wall Installation Option includes

Weatherhood	A full downturn design with a generous intake area to minimize intake velocity and moisture entrainment.
Thru-Wall Sleeve	Sleeve provides attachment interface between weatherhood and burner section. Accommodates walls up to 15 inches in depth.
Filter Section	Aluminum mesh media filters outdoor air and strips fine mist from the air. Drain pan is pitched back towards the intake to allow moisture to weep out the front of the wall sleeve.

Dimensions for Packaged DX Cooling - DGX only

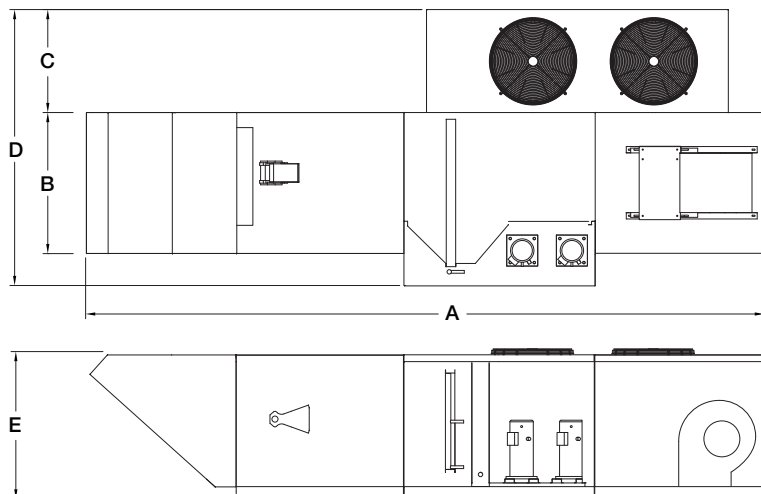

Model	Housing Size	Packaged DX Cooling				
		A	B	C	D	E
DGX	H12	156	33.8	25.5	70	39
	H22	212	45	32	87	45
	H32	237	52	35.5	99	49

All dimensions are in inches.



Model IG and IGX Indirect Gas-Fired

The IG and IGX features a 4-pass, 80% efficient indirect gas-fired furnace(s) which are ETL Listed.

Performance

Capacities is 15,000 cfm with up to 2 in. wg static pressure. Heating capacity ranges from 75,000 to 1,200,000 Btu/hr available.

Optional Evaporative Cooling

The evaporative cooling section includes a galvanized steel housing with a louvered intake, 2-inch aluminum mesh filters and a stainless steel evaporative cooling module. The CELdek® evaporative cooling media has a depth of 12 inches for 90% cooling effectiveness.

Optional Packaged Direct Expansion (PDX) - IGX only

The packaged DX cooling option is designed to cool the kitchen make-up air to a 70-75°F supply air condition to improve space comfort and enhance employee productivity at an economical first cost. The PDX option includes integral condenser fans, condenser and evaporator coils, thermal expansion valves, and compressors.

70

Model Housing Size	Best Available Program
IG-10 -20 -30	10 Days
IGX-12 -22 -32	
*IGX with PDX-12 -22 -32	15 Days

**Best Available based on housing size, capacity, coils and unit accessories.*

Standard Construction	IG	IGX
Galvanized steel unit construction (G90)	■	■
Power vented	■	■
Control center with starter and disconnect	■	■
Vibration isolation	■	■
Factory-wired and tested	■	■
Direct spark ignition system	■	■
Insulated double-wall furnace section construction	■	■
Options and Accessories	IG	IGX
Birdscreen weatherhood	■	■
Aluminum mesh filtered weatherhood		■
Louvered weatherhood	■	■
100% outdoor air	■	■
Recirculation	■	■
Variable air volume (VAV)		■
Staged furnace control	■	■
Modulating furnace 4:1 control	■	■
High turndown modulating furnace control (up to 16:1), patent pending		■
Remote panel	■	■
Aluminum or stainless steel heat exchanger	■	■
Network interface		■
Microprocessor control		■
Evaporative cooling	■	■
Packaged DX cooling		■
V-bank filter section	■	■
Outdoor air damper, inlet	■	■
Discharge air damper, outlet	■	■
Duct liner insulation	■	■
Double-wall construction	■	■
Exhaust fan starter	■	■
Dirty filter sensor	■	■
Freeze protection	■	■
Inlet air sensor, mild weather stat	■	■
Variable frequency drive (VFD)	■	■
Service receptacle	■	■
Auxiliary contacts	■	■
External gas pressure regulator	■	■
Roof curb	■	■
Duct adapter	■	■

Dimensions for IG

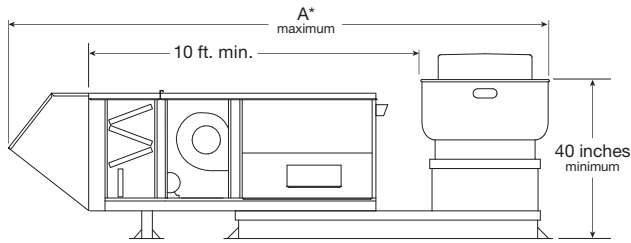

Combination Package - Arrangement DBC

Model	Housing Size	Arrangement DBC	
		A*	Width
IG	H10	182	48
	H20	183	52.5
	H30	181	52.5

All dimensions are in inches and include a weatherhood and 2-inch filter section.
*Based on largest available CUBE exhaust fan.

Dimensions for IGX

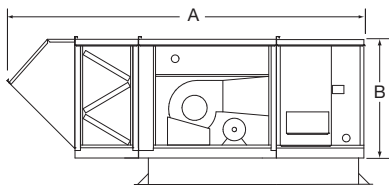

Stand-Alone - Arrangement DB/HZ

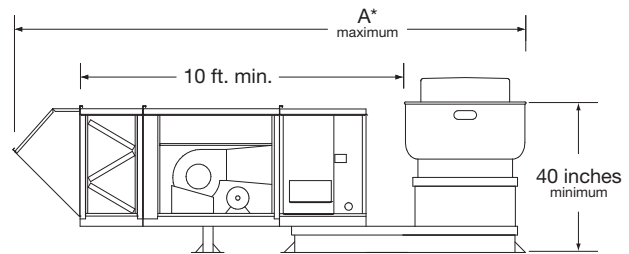

Combination Package - Arrangement DBC

Model	Housing Size	Arrangement DB/HZ		
		A	B	Width
IGX	H12	127.1	39	44.6
	H22	155.1 [^]	45	44.6+
	H32	172.3 [^]	48.7	52.2

All dimensions are in inches and include weatherhood and 2-inch filter section.

Model	Housing Size	Arrangement DBC	
		A*	Width
IGX	H12	174	44.6
	H22	224.3 [^]	44.6+
	H32	249.4 [^]	52.2

All dimensions are in inches and include a weatherhood and 2-inch filter section.
*Based on largest available CUBE exhaust fan.

[^] The A dimension is for units with only one furnace. Add 33.1 inches for each additional furnace.

+ Furnace section width is 44.6 inches for furnaces sizes 350 MBH or less. Width is 53.9 inches for furnaces greater than 350 MBH.

Dimensions for Packaged DX Cooling - IGX only

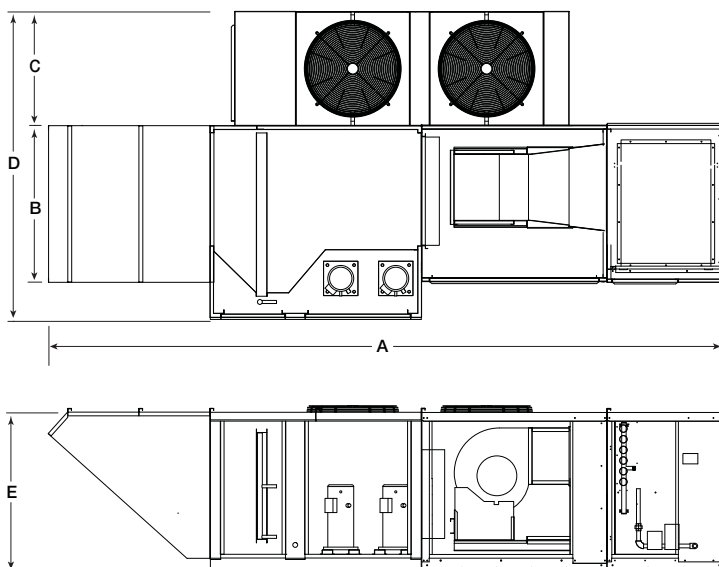

Model	Housing Size	Packaged DX Cooling				
		A	B	C	D	E
IGX	H12	151.8	44.1	29.1	73.2	39
	H22	192.2	44.1	32.1	86.3	45
	H32	216	52.2	35.3	100.1	48.7

All dimensions are in inches.

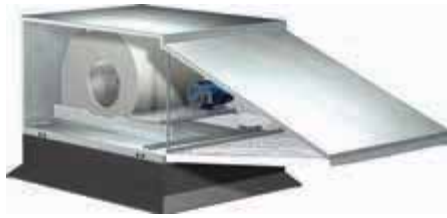

Best Available Program

5 Days

Model KSFD Direct Drive and KSFB Belt Drive - Untempered

Model KSFD and KSFB are designed to provide untempered make-up air for commercial and institutional kitchens. Installation may be stand-alone or on a combination curb with model CUBE exhaust fan.

Performance

A variety of blowers provide airflow capacities as high as 10,500 cfm with static pressures up to 2 in. wg.

Standard Arrangements

Model KSFD and KSFB have a compact design available with a horizontal discharge (arrangement HZ) or a downblast discharge (arrangement DB).

Installation may be as a stand-alone supply fan or a combination package with exhaust and supply fan on a common curb.

Combination Packages

The Greenheck combination package simplifies installation and reduces field labor costs. The pre-engineered design ensures that the supply fan, exhaust fan, curb and combination extension components interface properly.

Equally important, Greenheck combination packages are specifically designed to comply with NFPA 96.

Kitchen Fan Control Center (KFCC)

Prewired in compliance with the National Electrical Code, the KFCC simplifies field wiring, thereby reducing installation time and mistakes. The control center is a NEMA Type 1 panel for mounting indoors. It is designed to interlock with the fire suppression system.

Kitchen Supply Control Panel (KSCP)

The KSCP offers safety and reliability for remote operation. The standard NEMA Type 1 housing allows the panel to be mounted indoors. The panels can be provided with an optional kitchen hood light switch.



Options and Accessories	KSFD	KSFB
Kitchen fan control center (KFCC)	■	■
Kitchen supply control panel (KSCP)	■	■
Roof curb	■	■
Combo curb	■	■
Duct adapter	■	■
Damper	■	■
Speed controller	■	
Extended weatherhood	■	■
Horizontal or downblast discharge	■	■

Dimensions for KSFD, KSFB

Stand-Alone - Standard Weatherhood

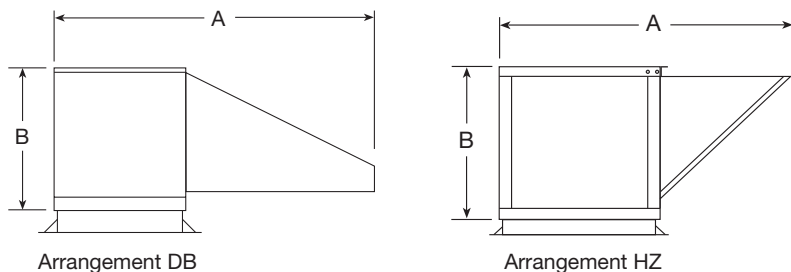

Housing Size	Arrangement DB		
	A	B	Width
H05	40.8	14.5	19.8
H08	40.8	14.5	36.8
H15	80.3	22.3	31.8
H25	99.3	29.5	40.0

Housing Size	Arrangement HZ		
	A	B	Width
H05	31.5	18.5	19.8
H08	31.5	18.5	36.8
H15	71.0	25.3	31.8
H25	81.3	34.0	40.0

Stand-Alone - Extended Weatherhood

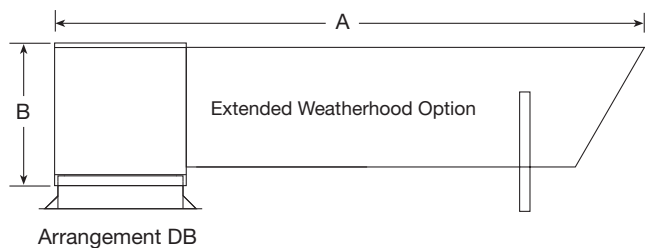

Housing Size	Arrangement DB		
	A	B	Width
H05	130.0	18.5	19.8
H08	124.8	18.5	36.8
H15	145.3	25.3	31.8
H25	152.5	34.0	40.0

3 ft. Vertical Separation Combination Package - Standard Weatherhood

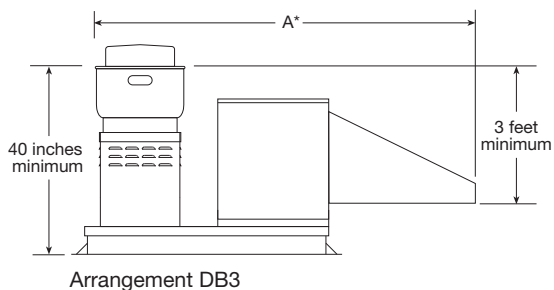

Housing Size	Arrangement DB3	
	A*	Width*
H05	70.0	25.0
H08	82.3	36.8
H15	131.5	42.8
H25	159.8	50.0

*Maximum dimension. Based on largest available CUBE exhaust fan.

10 ft. Horizontal Separation Combination Package - Extended Weatherhood

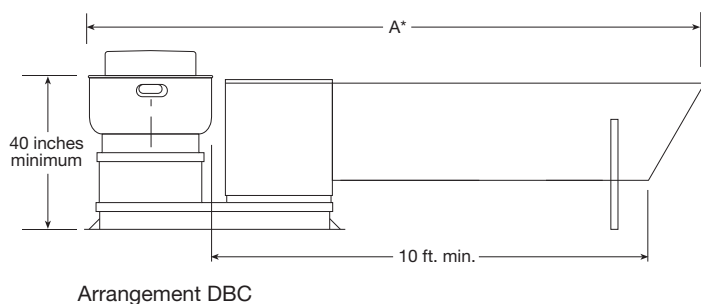

Housing Size	Arrangement DBC	
	A*	Width*
H05	159.3	25.0
H08	166.3	36.8
H15	196.5	42.8
H25	212.8	50.0

*Maximum dimensions. Based on largest available CUBE exhaust fan.

All dimensions are in inches. Consult your representative for dimensional data when the evaporative cooling option is selected.